

**IN THE UNITED STATES DISTRICT COURT  
FOR THE DISTRICT OF COLORADO**

Civil Action No. 13-CV-1300-MSK-MJW

~~JOHN B. COOKE, Sheriff of Weld County, Colorado;~~  
~~TERRY MAKETA, Sheriff of El Paso County, Colorado;~~  
~~JUSTIN SMITH, Sheriff of Larimer County, Colorado;~~  
~~DAVID A. WEAVER, Sheriff of Douglas County, Colorado;~~  
~~BRUCE W. HARTMAN, Sheriff of Gilpin County, Colorado;~~  
~~KEN PUTNAM, Sheriff of Cheyenne County, Colorado;~~  
~~DENNIS SPRUELL, Sheriff of Montezuma County, Colorado;~~  
~~TIM JANTZ, Sheriff of Moffat County, Colorado;~~  
~~JERRY MARTIN, Sheriff of Dolores County, Colorado;~~  
~~MIKE ENSMINGER, Sheriff of Teller County, Colorado;~~  
~~SHAYNE HEAP, Sheriff of Elbert County, Colorado;~~  
~~CHAD DAY, Sheriff of Yuma County, Colorado;~~  
~~FRED D. MCKEE, Sheriff of Delta County, Colorado;~~  
~~LOU VALLARIO, Sheriff of Garfield County, Colorado;~~  
~~FRED HOSSELKUS, Sheriff of Mineral County, Colorado;~~  
~~BRETT L. POWELL, Sheriff of Logan County, Colorado;~~  
~~JAMES FAULL, Sheriff of Prowers County, Colorado;~~  
~~LARRY KUNTZ, Sheriff of Washington County, Colorado;~~  
~~BRIAN E. NORTON, Sheriff of Rio Grande County, Colorado;~~  
~~DUKE SCHIRARD, Sheriff of La Plata County, Colorado;~~  
~~JIM BEICKER, Sheriff of Fremont County, Colorado;~~  
~~RONALD BRUCE, Sheriff of Hinsdale County, Colorado;~~  
~~CHRIS S. JOHNSON, Sheriff of Otero County, Colorado;~~  
~~FRED JOBE, Sheriff of Custer County, Colorado;~~  
~~DONALD KRUEGER, Sheriff of Clear Creek County, Colorado;~~  
~~JAMES CRONE, Sheriff of Morgan County, Colorado;~~  
~~SI WOODRUFF, Sheriff of Rio Blanco County, Colorado;~~  
~~TOM RIDNOUR, Sheriff of Kit Carson County, Colorado;~~  
~~TOM NESTOR, Sheriff of Lincoln County, Colorado;~~  
~~STAN HILKEY, Sheriff of Mesa County, Colorado;~~  
~~FORREST FRAZEE, Sheriff of Kiowa County, Colorado;~~  
~~RICK DUNLAP, Sheriff of Montrose County, Colorado;~~  
~~TED B. MINK, Sheriff of Jefferson County, Colorado;~~  
~~DAVE STONG, Sheriff of Alamosa County, Colorado;~~  
~~FRED WEGENER, Sheriff of Park County, Colorado;~~  
~~BRUCE NEWMAN, Sheriff of Huerfano County, Colorado;~~  
~~RANDY PECK, Sheriff of Sedgwick County, Colorado;~~  
~~DOMINIC MATTIVI, JR., Sheriff of Ouray County, Colorado;~~  
~~JOHN MINOR, Sheriff of Summit County, Colorado;~~

~~SCOTT FISCHER, Sheriff of Jackson County, Colorado;~~  
~~PETER GONZALEZ, Sheriff of Archuleta County, Colorado;~~  
~~RICK BESECKER, Sheriff of Gunnison County, Colorado;~~  
~~CHARLES "ROB" URBACH, Sheriff of Phillips County, Colorado;~~  
~~ROD FENSKE, Sheriff of Lake County, Colorado;~~  
~~GRAYSON ROBINSON, Sheriff of Arapahoe County, Colorado;~~  
~~DAVID D. CAMPBELL, Sheriff of Baca County, Colorado;~~  
~~MIKE NORRIS, Sheriff of Saguache County, Colorado;~~  
~~AMOS MEDINA, Sheriff of Costilla County, Colorado;~~  
~~MILES CLARK, Sheriff of Crowley County, Colorado;~~  
~~DAVID ENCINIAS, Sheriff of Bent County, Colorado;~~  
~~SUE KURTZ, Sheriff of San Juan County, Colorado;~~  
~~JAMES (JIM) CASIAS, Sheriff of Las Animas County, Colorado;~~  
~~GARRETT WIGGINS, Sheriff of Routt County, Colorado;~~  
~~DOUGLAS N. DARR, Sheriff of Adams County, Colorado;~~  
~~RODNEY JOHNSON, Sheriff of Grand County, Colorado;~~  
COLORADO OUTFITTERS ASSOCIATION;  
COLORADO FARM BUREAU;  
NATIONAL SHOOTING SPORTS FOUNDATION;  
MAGPUL INDUSTRIES;  
COLORADO YOUTH OUTDOORS;  
USA LIBERTY ARMS;  
OUTDOOR BUDDIES, INC.;  
WOMEN FOR CONCEALED CARRY;  
COLORADO STATE SHOOTING ASSOCIATION;  
HAMILTON FAMILY ENTERPRISES, INC., d/b/a FAMILY SHOOTING CENTER  
AT CHERRY CREEK STATE PARK;  
DAVID STRUMILLO;  
DAVID BAYNE;  
DYLAN HARRELL;  
ROCKY MOUNTAIN SHOOTERS SUPPLY;  
2ND AMENDMENT GUNSMITH & SHOOTER SUPPLY, LLC;  
BURRUD ARMS INC. D/B/A JENSEN ARMS;  
GREEN MOUNTAIN GUNS;  
JERRY'S OUTDOOR SPORTS;  
GRAND PRIX GUNS;  
SPECIALTY SPORTS & SUPPLY;  
GOODS FOR THE WOODS;

Plaintiffs,

vs.

JOHN W. HICKENLOOPER, Governor of the State of Colorado,

Defendant.

---

**~~SECOND~~ THIRD AMENDED COMPLAINT FOR DECLARATORY  
AND INJUNCTIVE RELIEF**

---

Peace officers and peaceable citizens join together to bring this action in defense of public safety, the Second and Fourteenth Amendments of the Constitution of the United States, and the Americans with Disabilities Act. Plaintiffs are 55 Colorado elected sheriffs, retired law enforcement officers, disabled individuals, civil rights and disability rights organizations, licensed firearms dealers, associations of law-abiding gun owners, hunting outfitters, and the firearms industry, and a manufacturer of firearm accessories.

**I. OVERVIEW**

1. On March 20, 2013, Colorado Governor John Hickenlooper signed two measures that severely restrict citizens' rights to own, use, manufacture, sell, or transfer firearms and firearms accessories.

**HB 1224**

2. House Bill 13-1224 ("HB 1224") bans outright all ammunition magazines sold or acquired after July 1, 2013 that hold more than 15 rounds of ammunition. HB 1224 also bans most other magazines of any size because it prohibits smaller magazines that are "designed to be readily converted" to hold more than 15 rounds of ammunition.

3. The magazines for most handguns and for many rifles are detachable box magazines. The very large majority of magazines contain a removable floor plate. The removable floor plate allows the user to clear ammunition jams, clean the inside of the magazine, and perform maintenance on the internal mechanics of the magazine.

4. The fact that a magazine floor plate can be removed inherently creates the possibility that the magazine can be extended through commercially available extension products or readily fabricated extensions. As a result, nearly every magazine can be readily converted to exceed the capacity limit set by HB 1224.

5. Some rifles have fixed box magazines, which are permanently attached to the rifle. Many of these also have removable floor plates.

6. Instead of a box magazine, some rifles have fixed tube magazines, which lie underneath the rifle barrel. Many tube magazines have removable end caps for cleaning to which extenders can be added. A ban on certain types of fixed magazines is necessarily a ban on the rifles to which they are fixed.

7. The Appendix to this Complaint contains diagrams showing the parts of a detachable box magazine and a fixed tube magazine.

8. Magazine capacity can be increased in many other ways, such as snipping the spring inside the magazine so that there is more space to accommodate additional rounds, using a coupler so that a second box magazine is attached (upside down) to the bottom of another, or simply using duct tape instead of a coupler.

9. The chief sponsor of HB 1224 and Governor Hickenlooper have both publicly confirmed that HB 1224 bans all magazines with removable floor plates.

10. By outlawing most box and tube magazines, HB 1224 outlaws an essential component of many common firearms. Eighty-two percent of handguns and at least one-third of rifles currently manufactured in the United States are semi-automatic, which means that most of them store their ammunition in detachable box magazines. Rifles which use box or tube magazines are not limited to semi-automatics, but also include pump action, bolt action, and lever action rifles. (HB 1224 exempts lever action guns which use tube magazines, but not lever action guns which use box magazines; the bill also exempts rimfire rifles which use tube magazines, but does not exempt such rifles that use box magazines.)

11. Thus, the magazine ban amounts to a ban on having a functional, operating unit for most handguns and a very large fraction of rifles – a patent violation of the Second and Fourteenth Amendments under *District of Columbia v. Heller*, 554 U.S. 570 (2008) and *McDonald v. Chicago*, 130 S. Ct. 3020 (2010).

12. As detailed *infra*, HB 1224 allows the possession of grandfathered magazines only if two separate requirements are satisfied: First, they must be owned on July 1, 2013. Second, the owner must maintain “continuous possession” of the magazine.

13. The requirement for “continuous possession” makes it impossible for firearms to be used or shared in ordinary and innocent ways, such as a gun owner loaning his or her firearm with the magazine to a spouse, family member, or friend;

entrusting it to a gunsmith for repair; a military reservist leaving firearms and their associated magazines with a spouse when he or she is called into service away from home; or even temporarily handing a firearm with its magazine to a firearms safety instructor so that the owner can be shown by the instructor how to better grip, aim, or otherwise use the firearm.

14. The requirement of “continuous possession” prohibits the grandfathered owner from ever allowing anyone to hold or use his firearm if the firearm is in a functional state (with a magazine inserted) – an extreme infringement of Second Amendment rights.

15. In *Heller*, the Supreme Court adopted a rule enforcing the Second Amendment that prohibited the banning of arms “typically possessed by law-abiding citizens for lawful purposes.” The ban against all magazines holding more than 15 rounds violates this rule. Rifles with magazines larger than 15 rounds are so commonplace that many models are supplied in a *standard* 30-round configuration. Indeed, one such rifle is the AR-15 and its many variants, which has for years been one of the best-selling types of firearms in the United States and of which there are at least four million in the United States today. The number of other models of Modern Sporting Rifles is likewise in the millions, which are also often sold with magazines holding more than 15 rounds.

16. Similarly, many popular handguns are sold with magazines with 16 to 20-round capacities. Many gun owners own several magazines for each firearm. The

number of magazines in the United States which are of the size directly outlawed by HB 1224 is in the tens of millions.

17. Disabled citizens, whose disabilities often make it difficult to change magazines quickly, are acutely harmed by HB 1224. This is a particularly grave violation of their Second Amendment rights, especially their right to self-defense in the home.

18. HB 1224 also violates Title II of the Americans with Disabilities Act (“ADA”). Even assuming that HB 1224 is constitutional, all persons with relevant disabilities are entitled to an accommodation under the ADA so that they may possess and acquire the magazine in the sizes they need.

19. The effect of HB 1224’s various provisions is the widespread ban on functional firearms. The prohibition of so many box and tube magazines of any size, and the prohibition of magazines greater than 15 rounds, directly and gravely harm the ability of law-abiding citizens to use firearms for lawful purposes, especially self-defense.

### **HB 1229**

20. House Bill 13-1229 (“HB 1229”) requires “universal” background checks before any sale or transfer of a firearm can occur, with some exceptions. HB 1229, even considering the exceptions, prohibits a wide range of common, temporary, or permanent transfers or loans of firearms between law-abiding citizens in violation of the Second Amendment.

21. As a practical matter, it will be impossible for citizens to comply with HB 1229. The bill requires that when one individual sells or loans a firearm to another, that “transfer” must be conducted through a Federal Firearms Licensee (“FFL,” a licensed gun dealer). The FFL is required to process the transfer as if he or she is selling a firearm out of his or her own inventory. HB 1229 allows the FFL to charge a fee of no more than \$10 for conducting the transfer.

22. Many FFLs in Colorado, including FFL Plaintiffs, are unwilling to conduct the transfer under such conditions. Accordingly, it will be extremely difficult, if not impossible, for many Coloradans to find a FFL to conduct the transfers, even if the buyer and seller are both willing and able to drive long distances to do so.

23. To conduct the transfer pursuant to HB 1229, the FFL must complete the same paperwork as if he or she were selling from his or her own inventory. This means that for each firearm transferred, a three-page federal form (ATF Form 4473) must be filled out. Some parts of the form are filled out by the customer, and some by the FFL. FFLs are liable for errors on a Form 4473 and subject to license revocation and even federal felony charges.

24. FFLs must monitor the transferor and transferee for as long as it takes to complete the transaction. The “instant check” which is conducted by the Colorado Bureau of Investigation often takes hours, and sometimes days, to complete.

25. Currently, when FFLs are asked to conduct a background check for a firearm, not involving a profitable sale from the FFL’s actual inventory, the fee



charged may be \$50. A fee cap of \$10 will likely result in very few, if any, FFLs being willing to perform the services which are necessary for transfers under HB 1229, making compliance with HB 1229 next to impossible in many private transfer situations.

26. Moreover, setting aside the myriad problems with compliance with HB 1229, the scope of HB 1229's regulation, which impacts a vast array of innocent and lawful temporary transfers among friends and members of various hunting and shooting organizations, unconstitutionally infringes the Second Amendment rights of tens of thousands of Coloradans.

### **The Supreme Court's Landmark Decisions: *Heller* and *McDonald***

27. There are certain indisputable legal principles announced by the United States Supreme Court against which HB 1224 and HB 1229 must be judged.

28. Under *Heller*, the Second Amendment to the United States Constitution guarantees the right of individual citizens to keep and bear commonly-used firearms for all lawful purposes.

29. The individual right to employ commonly-used firearms for self-defense is "the central component" of the Second Amendment guarantee.

30. An individual's Second Amendment rights, including the right to self-defense, are fundamental rights.

31. Under *McDonald*, the rights protected by the Second Amendment apply equally to the states, including Colorado, through the Fourteenth Amendment to the United States Constitution.

32. HB 1224 and HB 1229 violate these principles.

## II. JURISDICTION AND VENUE

33. This Court has jurisdiction over this matter pursuant to 28 U.S.C. § 1331 because the claims arise under the Constitution and statutes of the United States.

34. This Court has jurisdiction to grant the declaratory relief sought pursuant to 18 U.S.C. § 2201, and additional relief pursuant to 18 U.S.C. § 2202.

35. This Court also has jurisdiction under 28 U.S.C. § 1343(a)(3) and 42 U.S.C. § 1983 because this action involves a deprivation of federal constitutional rights by those acting under color of state law.

36. Venue is proper in this district pursuant to 28 U.S.C. § 1391.

## III. PARTIES

### A. Plaintiffs

#### ~~1. The Sheriffs of 55 Colorado Counties~~

~~37. Each of the following Sheriffs of 55 Colorado counties (“the Sheriffs”) has the primary obligation to obey the Constitution of the United States of America. The Sheriffs bring this case pursuant to this primary obligation, which is supreme over any other purported enactment.~~

~~38. John B. Cooke is the Sheriff of Weld County, Colorado.~~

~~39. Terry Maketa is the Sheriff of El Paso County, Colorado.~~

~~40. Justin Smith is the Sheriff of Larimer County, Colorado.~~

~~41. David A. Weaver is the Sheriff of Douglas County, Colorado.~~

~~42. Bruce W. Hartman is the Sheriff of Gilpin County, Colorado.~~

43. ~~Ken Putnam is the Sheriff of Cheyenne County, Colorado.~~
44. ~~Dennis Spruell is the Sheriff of Montezuma County, Colorado.~~
45. ~~Tim Jantz is the Sheriff of Moffat County, Colorado.~~
46. ~~Jerry Martin is the Sheriff of Dolores County, Colorado.~~
47. ~~Mike Ensminger is the Sheriff of Teller County, Colorado.~~
48. ~~Shayne Heap is the Sheriff of Elbert County, Colorado.~~
49. ~~Chad Day is the Sheriff of Yuma County, Colorado.~~
50. ~~Fred D. McKee is the Sheriff of Delta County, Colorado.~~
51. ~~Lou Vallario is the Sheriff of Garfield County, Colorado.~~
52. ~~Fred Hosselkus is the Sheriff of Mineral County, Colorado.~~
53. ~~Brett L. Powell is the Sheriff of Logan County, Colorado.~~
54. ~~James Faulk is the Sheriff of Prowers County, Colorado.~~
55. ~~Larry Kuntz is the Sheriff of Washington County, Colorado.~~
56. ~~Brian E. Norton is the Sheriff of Rio Grande County, Colorado.~~
57. ~~Duke Schirard is the Sheriff of La Plata County, Colorado.~~
58. ~~Jim Beieker is the Sheriff of Fremont County, Colorado.~~
59. ~~Ronald Bruce is the Sheriff of Hinsdale County, Colorado.~~
60. ~~Chris S. Johnson is the Sheriff of Otero County, Colorado.~~
61. ~~Fred Jobe is the Sheriff of Custer County, Colorado.~~
62. ~~Donald Krueger is the Sheriff of Clear Creek County, Colorado.~~
63. ~~James Crone is the Sheriff of Morgan County, Colorado.~~
64. ~~Si Woodruff is the Sheriff of Rio Blanco County, Colorado.~~

65. ~~Tom Ridnour is the Sheriff of Kit Carson County, Colorado.~~
66. ~~Tom Nestor is the Sheriff of Lincoln County, Colorado.~~
67. ~~Stan Hilkey is the Sheriff of Mesa County, Colorado.~~
68. ~~Forrest Frazee is the Sheriff of Kiowa County, Colorado.~~
69. ~~Riek Dunlap is the Sheriff of Montrose County, Colorado.~~
70. ~~Ted B. Mink is the Sheriff of Jefferson County, Colorado.~~
71. ~~Dave Stong is the Sheriff of Alamosa County, Colorado.~~
72. ~~Fred Wegener is the Sheriff of Park County, Colorado.~~
73. ~~Bruce Newman is the Sheriff of Huerfano County, Colorado.~~
74. ~~Randy Peck is the Sheriff of Sedgwick County, Colorado.~~
75. ~~Dominic Mattivi, Jr., is the Sheriff of Ouray County, Colorado.~~
76. ~~John Minor is the Sheriff of Summit County, Colorado.~~
77. ~~Scott Fischer is the Sheriff of Jackson County, Colorado.~~
78. ~~Peter Gonzalez is the Sheriff of Archuleta County, Colorado.~~
79. ~~Riek Besecker is the Sheriff of Gunnison County, Colorado.~~
80. ~~Charles "Rob" Urbach is the Sheriff of Phillips County, Colorado.~~
81. ~~Rod Fenske is the Sheriff of Lake County, Colorado.~~
82. ~~Grayson Robinson is the Sheriff of Arapahoe County, Colorado.~~
83. ~~David D. Campbell is the Sheriff of Baca County, Colorado.~~
84. ~~—Mike Norris is the Sheriff of Saguache County, Colorado.~~
85. ~~—Amos Medina is the Sheriff of Costilla County, Colorado.~~
86. ~~—Miles Clark is the Sheriff of Crowley County, Colorado.~~

87. —~~David Encinias is the Sheriff of Bent County, Colorado.~~
88. —~~Sue Kurtz is the Sheriff of San Juan County, Colorado.~~
89. —~~James (Jim) Casias is the Sheriff of Las Animas County, Colorado.~~
90. —~~Garrett Wiggins is the Sheriff of Routt County, Colorado.~~
91. —~~Douglas N. Darr is the Sheriff of Adams County, Colorado.~~
92. —~~Rodney Johnson is the Sheriff of Grand County, Colorado.~~

93. ~~HB 1224 and 1229 violate the Constitution of the United States. The Sheriffs cannot enforce a statute that violates the fundamental constitutional rights of the citizens of Colorado.~~

94. ~~For reasons detailed *supra* and *infra*, HB 1224 and 1229 are utterly unenforceable, even if the Sheriffs wished to violate the U.S. Constitution.~~

95. ~~After HB 1229 becomes effective, every citizen of Colorado can legally possess a “large capacity” magazine that holds more than 15 rounds so long as they owned it prior to the effective date and maintain “continuous possession” of it after the effective date. This includes both magazines that hold more than 15 rounds, and smaller magazines with removable floor plates or end caps. At least hundreds of thousands of Colorado citizens, including the individual Plaintiffs and members of Plaintiff associations, will lawfully own hundreds of thousands (or more) of such magazines.~~

96. ~~The Sheriffs have limited resources and limited public funds to spend on investigations. They cannot expend those resources to conduct investigations that would be necessary to monitor compliance with the new magazine restrictions.~~

~~No documentation has ever been required for the retail or private purchase of magazines, making it a practical impossibility for the Sheriffs to determine whether one of the many magazines already in existence was obtained after the effective date.~~

97. ~~It would be similarly impossible to determine whether a magazine was in the “continuous possession” of its owner after July 1, 2013.~~

98. ~~With very few exceptions, magazines manufactured in other states are not required to bear date stamps, making it impossible to determine their date of manufacture. The Sheriffs will have no means to determine whether a magazine possessed by an individual in Colorado was manufactured before or after July 1, 2013, with the exception of those manufactured in Colorado after July 1, 2013 that are required by the bill to bear a date stamp.~~

99. ~~The foregoing presumes that it is clear what the bill prohibits. But the Sheriffs’ enforcement obstacles become insurmountable if they must also resolve ambiguities in the bill. If the bill does not prohibit every magazine with a removable floor plate and end cap, but only those that were intentionally “designed” for the purpose of expanding capacity, the Sheriffs are given no tools to make that determination. They cannot know the intent of the designer.~~

100. ~~Likewise, each Sheriff will have to determine what constitutes “continuous possession,” since the statute provides no guidance. They will have to make individual decisions whether continuous possession allows for temporary loans to others and, if so, for what duration.~~

101. ~~In addition to the core infringement on a fundamental right inherent in any enforcement of these provisions, the result of the many ambiguities will be varying individual decisions and inconsistent enforcement across jurisdictions. Effective law enforcement depends on close and supportive relations between the public and law enforcement. Unconstitutional, vague laws which are inconsistently enforced poison that relationship, and make it significantly more difficult for the Sheriffs to receive the witness cooperation, tips, and other forms of public support which are necessary to effective law enforcement in a free society.~~

102. ~~Sheriffs have the common law power to request the armed assistance of able-bodied adults in their County. This is known as the “posse comitatus.” One well-known use of the posse in Colorado was in June 1977, when Pitkin County citizens with their own guns responded to a request to help with the search for escaped mass murderer Theodore Bundy.~~

103. ~~Sheriffs also have the authority to appoint deputies who are not certified peace officers. The “non-certified” deputies may be appointed for a limited period of time, or for specific tasks. C.R.S. §§ 16-2.5-103(2); 30-10-506. Particularly in rural parts of Colorado, Sheriffs utilize the authority to deputize individuals to augment law enforcement efforts in times of disturbances and natural disasters.~~

104. ~~When those Sheriffs deputize, they do not have a cache of firearms to issue. Moreover, a person who is deputized in an emergency will be safer and more effective using his or her personal firearm, with which he or she is already familiar.~~

105. ~~HB 1224 seriously impedes the ability of Sheriffs to call upon armed citizen assistance during emergencies and natural disasters because it prevents citizens from having the types of magazines which the Sheriffs and their ordinary deputies have determined to be most effective for the preservation of public safety. As described in paragraphs 95, 137, 158, 187, 207, 214, 217, and 231, the Sheriffs, like all Plaintiffs, are injured by the infringements of their individual rights under the Second and Fourteenth Amendments. The infringements of the Sheriffs' rights are particularly harmful because of the heightened danger that the Sheriffs and their families presently face and will continue to face after retirement as the result of the Sheriffs' public service.~~

**1. Plaintiff Sheriffs, in the personal capacities**

**a. Background of Sheriff Plaintiffs**

106. The Fifty-five Plaintiffs are individual citizens who are career law enforcement officers and who are presently elected Sheriffs. The aforesaid Plaintiffs are suing in their individual capacities as American citizens with individual rights under the Second and Fourteenth Amendments. Because all of them happen to be, at this time, elected Sheriffs, this Complaint refers to them as "the Sheriffs" for concision.

107. John B. Cooke has served nearly 35 years in law enforcement. He has five years of experience with the Breckenridge Police Department, and has served 29 years and 8 months with the Weld County Sheriff's Office, including 11 as Sheriff. Because of term limits, he will complete his law enforcement career in January 2015. Like several other Sheriffs, Cooke and his family have been the



victims of identifiable threats; those threats are described in Exhibit A (at 4-6) to this Complaint. All Exhibits to this Complaint are incorporated by reference.

108. Terry Maketa is the Sheriff of El Paso County, Colorado. He has 26 years of law enforcement experience, all of them with the El Paso County Sheriff's Office. He is the first person in the Office's history to rise all the way through every rank and then become Sheriff.

109. Justin Smith is the Sheriff of Larimer County, Colorado. He has 27 years law enforcement experience, 13 of them in command ranks. If he continues to be re-elected, his law enforcement service will end in January 2019.

110. David A. Weaver is the Sheriff of Douglas County, Colorado. He has over 32 years of law enforcement experience, and has worked in nearly every area of police administration.

111. Bruce W. Hartman is the Sheriff of Gilpin County, Colorado. He is currently serving his fifth term as Sheriff and was originally elected in 1992.

112. Ken Putnam is the Sheriff of Cheyenne County, Colorado. He has 18 years of law enforcement experience, and will finish his service as Sheriff in January 2015.

113. Dennis Spruell is the Sheriff of Montezuma County, Colorado. He has 33 years in law enforcement, with 27 years as a Supervisor, including as a K-9 Officer and director of a multijurisdictional drug task force. Sheriff Spruell has been Sheriff for three years and will be term limited in 2021, if he is re-elected.

114. Tim Jantz is the Sheriff of Moffat County, Colorado. He has 33 years of law enforcement, 14 of them at the supervisory level.

115. Jerry Martin is the Sheriff of Dolores County, Colorado. He has 27 years of law enforcement experience, and his serving his sixth term as Sheriff.

116. Mike Ensminger is the Sheriff of Teller County, Colorado. He retired from the San Diego County Sheriff's office in 1987, and moved to Colorado. From 1988 to 2010, he was a Professor of Criminal Justice at Pikes Peak Community College. He was elected Sheriff in 2010.

117. Shayne Heap is the Sheriff of Elbert County, Colorado. He has 12 years in law enforcement, three of them as Sheriff. He is a member of the Elizabeth C-1 School Safety Board.

118. Chad Day is the Sheriff of Yuma County, Colorado. He has 11 years of law enforcement experience.

119. Fred D. McKee is the Sheriff of Delta County, Colorado. He has 31 years of law enforcement experience, including 10 as Sheriff. If he is re-elected in 2014, he plans to retire after the end of his term in January 2019.

120. Lou Vallario is the Sheriff of Garfield County, Colorado. He has 26 years of law enforcement experience, and served with the Glenwood Springs Police Department before being elected Sheriff.

121. Fred Hosselkus is the Sheriff of Mineral County, Colorado. He was first elected in 2006, and previously served as a deputy in the Office.

122. Brett L. Powell is the Sheriff of Logan County, Colorado. He has 17 years of law enforcement experience.

123. James Faull is the Sheriff of Prowers County, Colorado. He has 37 years of law enforcement experience—14 as Sheriff, and 23 years with a police department (15 of those in command positions). He plans on retiring at the end of his term in January 2015.

124. Larry Kuntz is the Sheriff of Washington County, Colorado. He will retire in January 2015 at the completion of his third term. He has 36 years of law enforcement experience, including as a city police officer and a Sheriff's deputy. Part of the reason for his retirement is regulatory changes that he feels put citizens in jeopardy, and that endanger law enforcement officers. These changes include HB 1224's de facto prevention of law enforcement officers and citizens, including himself, from acquiring standard capacity magazines holding 16 or more rounds.

125. Brian E. Norton is the Sheriff of Rio Grande County, Colorado. He has 26 years of law enforcement experience, including nine as Undersheriff and 11 as Sheriff.

126. Duke Schirard is the Sheriff of La Plata County, Colorado. He has 39 years of law enforcement experience, including as Sheriff's deputy, police officer, town marshal, and Sheriff.

127. Jim Beicker is the Sheriff of Fremont County, Colorado. He has 27 years of law enforcement experience, including 10 as Sheriff.

128. Ronald Bruce is the Sheriff of Hinsdale County, Colorado. He joined the Arizona Department of Public Safety – Highway Patrol Bureau in 1974, and retired therefrom on October 31, 2002. His wife retired as an Arizona Trooper that same day, after 22 years of service. He was elected Sheriff of Hinsdale County in 2006.

129. Chris S. Johnson is the Sheriff of Otero County, Colorado. He has 35 years of law enforcement experience, and has been Sheriff for 11 years.

130. Fred Jobe has been the Sheriff of Custer County, Colorado, for 28 years, and he has 39 years of law enforcement experience. He plans to retire at the end of his current term, in January 2015.

131. Donald Krueger is the Sheriff of Clear Creek County, Colorado. He has 25 years of full-time law enforcement experience, plus 14 years as a reserve officer. He has been Sheriff for 19 years and will retire at the end of his term in January 2015.

132. James Crone is the Sheriff of Morgan County, Colorado. He has served as Sheriff for 15 years, and had 19 years of law enforcement experience before that.

133. Si Woodruff is the Sheriff of Rio Blanco County, Colorado. He has 39 years of law enforcement experience, as Police officer, Senior patrol officer, Chief of Police, and then Sheriff.

134. Tom Ridnour is the Sheriff of Kit Carson County, Colorado. He has previously served as an investigator for the Colorado Department of Corrections as well as a police officer for the City of Burlington.

135. Tom Nestor is the Sheriff of Lincoln County, Colorado. He has been with the Lincoln County Sheriff's Office for 24 years. He previously served as Undersheriff.

136. Stan Hilkey is the Sheriff of Mesa County, Colorado. He has 27 years of law enforcement experience. He is term limited, and his final term ends in January 2015.

137. Forrest Frazee is the Sheriff of Kiowa County, Colorado. After retiring from a long career in the U.S. Navy, he was elected Sheriff in 2006.

138. Rick Dunlap is the Sheriff of Montrose County, Colorado. He has 23 years of law enforcement experience, including seven as Sheriff. If he is re-elected in 2014, his service as Sheriff will end in January 2019.

139. Ted B. Mink is the Sheriff of Jefferson County, Colorado. He will complete his final term as Sheriff in January 2015. Before being appointed Sheriff in July 2003, he had served as Undersheriff in Jefferson County. He was an officer with the Arvada Police Department from September 1977 until January 2003, and had been Deputy Chief of Police since 1998.

140. Dave Stong is the Sheriff of Alamosa County, Colorado. He has 40 years law enforcement experience, 20 of them as Sheriff. He will retire in January 2015.

141. Fred Wegener is the Sheriff of Park County, Colorado. He has been in law enforcement for 26 years, and prior to that was a military police officer for six years.

142. Bruce Newman is the Sheriff of Huerfano County, Colorado. He has 26 years law enforcement experience, including a year at the federal Supermax.

143. Randy Peck is the Sheriff of Sedgwick County, Colorado. He has been Sheriff for three years, and before that had 20 years of experience as a Deputy sheriff, Sergeant, and Undersheriff.

144. Dominic Mattivi, Jr., is the Sheriff of Ouray County, Colorado. He was first elected in 2002, and before that was a deputy in the Office.

145. John Minor is the Sheriff of Summit County, Colorado. He has served in law enforcement since 1990. His service includes four months as Acting Chief of Police in Silverthorne. He has been Sheriff since 2004. If he is re-elected in 2014, term limits will bring his service to an end in January 2019.

146. Scott Fischer is the Sheriff of Jackson County, Colorado. He has 16 years of law enforcement experience, including as State Trooper and Undersheriff.

147. Peter Gonzalez is the Sheriff of Archuleta County, Colorado. He has 42 years of law enforcement experience, including six years as Chief of Police in Ignacio, Colorado. He will retire in January 2015, after completing eight years of service as Sheriff.

148. Rick Besecker is the Sheriff of Gunnison County, Colorado. He has 41 years of law enforcement experience divided between the Saguache County Sheriff's Office, the Gunnison Police Department and Gunnison County Sheriff's Office.

149. Charles "Rob" Urbach is the Sheriff of Phillips County, Colorado. He joined the Office in 2002. He previously served in the Summit County Sheriff's Office.

150. Rod Fenske is the Sheriff of Lake County, Colorado. He has 29 years of law enforcement experience, including as Police Chief.

151. Grayson Robinson is the Sheriff of Arapahoe County, Colorado. His law enforcement career began with the Littleton Police Department in 1972, and he became a Division Commander in 1979. In 1992, he joined the Arapahoe County Sheriff's Office. He became Undersheriff in 1995, and was elected Sheriff in 2002.

152. David D. Campbell is the Sheriff of Baca County, Colorado.

153. Mike Norris is the Sheriff of Saguache County, Colorado. Previously, he served as Undersheriff, and before that as a deputy.

154. Amos Medina is the Sheriff of Costilla County, Colorado. He has 23 years of experience with the Office, and was elected in 2010.

155. Miles Clark is the Sheriff of Crowley County, Colorado. He was first elected in 2005, and had previously served as Undersheriff.

156. David Encinias is the Sheriff of Bent County, Colorado. He has over 29 years of experience in law enforcement.

157. Sue Kurtz is the Sheriff of San Juan County, Colorado. She has 31 years of law enforcement experience, as Sheriff, Undersheriff, Deputy sheriff, and District Attorney investigator. She will retire at the end of her current term in January 2015.

158. James (Jim) Casias is the Sheriff of Las Animas County, Colorado. He has 30 years of law enforcement experience, including as Undersheriff, Acting Chief of Police for the City of Trinidad, and other positions with the Las Animas Sheriff's Office and City of Trinidad Police Department.

159. Garrett Wiggins is the Sheriff of Routt County, Colorado. He began his law enforcement career on January 1, 1986, in Florida, at age 19. He worked for the Quincy Police Department full time for approximately 8.5 years and part-time on the reserve for approximately one year. During the past 15 years he has worked for the Steamboat Springs Police Department and for the Routt County Sheriff's Office. During five of his years with Steamboat, he was the Taskforce Commander for the All Crimes Enforcement Team as a supervisor and undercover narcotics investigator.

160. Douglas N. Darr is the Sheriff of Adams County, Colorado. He took office in January 2003, and will complete his service as Sheriff in January 2015.

161. Rodney Johnson is the Sheriff of Grand County, Colorado. He has 29 years of law enforcement experience.

162. While the individual Sheriffs do keep and bear arms pursuant to their duties as Sheriffs, the individual Sheriffs also own and use firearms and



magazines personally. Moreover, almost all of the Sheriffs' duty firearms and magazines are personally owned by the Sheriffs. Like the other plaintiffs in this case, the Sheriffs keep and bear arms for a wide variety of lawful purposes of arms ownership, all such purposes being protected by the Second Amendment. *District of Columbia v. Heller*, 554 U.S. 570, 577, 620, 624, 625, 628, 630 (2008) ("lawful purpose" or "lawful purposes"); *McDonald v. Chicago*, 130 S.Ct. 3020, 3023, 3030, 3036, 3044 (2010) (same). Every Sheriff in this case is a law-abiding citizen of the United States of America. As such, every Sheriff has an individual Second Amendment right to keep and bear arms, and an individual Fourteenth Amendment right not to be subject to vague laws which chill the exercise of the Second Amendment rights. The Sheriffs, like all Plaintiffs, are injured by the infringements of their individual rights under the Second and Fourteenth Amendments. The infringements of the Sheriffs' rights are particularly harmful because of the heightened danger that the Sheriffs and their families presently face and will continue to face after retirement as the result of the Sheriffs' public service.

#### **b. Threats to Sheriffs**

163. Sheriffs have a particularly great personal need to exercise the "core" Second Amendment right of lawful self-defense, "hearth," "home" and "family." *Heller*, 554 U.S. at 573-75, 577, 615-16, 625, 628-630, 632, 634-36; *McDonald*, 130 S.Ct. at 3026-27, 3036, 3039, 3041, 3044, 3047, 3049-50. Sheriffs are often away from their home. Disgruntled or mentally ill persons sometimes come to their homes and threaten family members. Such threats to family members also materialize away from home. One reason the Sheriffs wish to personally own firearms and

magazines is to share them with or permanently give them to family members who need them for self-defense. Credible threats to the families are common, including within the last year

164. Especially in lower-population communities, it is impossible for out-of-uniform Sheriffs or their families to blend into the background. Almost everyone knows who they are and where they live.

165. Moreover, all of the Sheriffs know that they will eventually retire from their positions as law enforcement officers. At that time, the limited law enforcement exemption of HB 1224 will not apply to them. Yet for the rest of the lives they and their families will continue to face the danger of retaliation from the many criminals whom they have arrested, or from any other person who may bear a grudge. Their current public service in law enforcement makes their and their families' present and post-retirement needs for armed self-defense particularly acute.

166. The Sheriffs and their families have already made substantial sacrifices for the public interest. It is in the public interest that they not be forced to face even greater risks by being disarmed from using the magazines and firearms that they have decided are the best for family protection.

167. Additional information about threats to certain Sheriffs and their families, and the defensive firearms and magazines used by the Sheriffs and their families, is detailed in Exhibits A and B to this Complaint. For personal safety reasons for the Sheriffs and their families, Exhibits A and B have been filed

separately, accompanying a Motion for Leave to Restrict, Level 1. Exhibit A is excerpted from confidential portions of Defendant's depositions of six Sheriffs, in which Defendant's counsel asked the Sheriffs many personal questions about their firearms collections, hunting experience, personal history of gun use, and about personal threats against the Sheriffs and their families. Exhibit B contains Declarations from several other Sheriffs about personal threats to them and their families, and some of the defensive firearms and magazines owned by those Sheriffs. See also Declaration of Sheriff Garrett Wiggins, paras. 2-4 (Exhibit B to Plaintiffs' Reply Brief for Preliminary Injunction (#41)).

**c. Sheriffs' personal firearms and magazines**

168. All of the Sheriffs and their families personally own firearms. They believe that law enforcement officers and all other law-abiding citizens should fully and equally enjoy the same Second and Fourteenth Amendment rights. Exhibits A (deposition excerpts) and B (declarations) to this Complaint provide details about some of the firearms and magazines owned by some of the individual Sheriffs, including magazines affected by HB 1224.

169. Except for Rick Dunlap, Jim Faull, Scott Fischer, Peter Gonzalez, and Tom Ridenour, all of the Sheriffs and their families personally own magazines for self-defense which accept more than 15 rounds. All of the Sheriffs and their families personally own magazines which accept 15 or fewer rounds. All the Sheriffs wish to be able to buy magazines of more than 15 rounds, now and in the future.

170. Some of the firearms and magazines which the Sheriffs and their families own were purchased in part for use in law enforcement duties; others were acquired and are used purely for personal reasons.

**i. Magazines of greater than 15 rounds**

171. All of the Sheriffs know that as they continue to age, their physical capabilities will change. They know that their reaction speeds, mobility, fine motor skills, and upper body strength will decline. As a statistical certainty, some the Sheriffs will become disabled. As detailed in the expert report of Massad Ayoob, older persons and the disabled have a particularly strong need for magazines which hold more than 15 rounds. Ayoob Report at 3-4 (Exhibit 17 to #70).

172. All the Sheriffs wish to be able to possess, purchase, own, loan, and sell 16-round and larger magazines over the course of their entire lives, including the portions of those lives which follow retirement from law enforcement. They wish to do so based on their individual determinations that such magazines are often the best choice for lawful self-defense for themselves and their families, based on individual circumstances now and in the future.

173. At present, the Sheriffs wish to be able to purchase additional magazines holding more than 15 rounds for their personal use in their law enforcement duties, and for other purposes. Their ability to do so is entirely thwarted, or significantly impaired; HB 1224's general prohibition on the sale of banned magazines contains no exceptions allowing a store to possess or sell such magazines within Colorado to Colorado law enforcement employees. See Sheriffs'

Response Brief on Motion to Dismiss at 34-37 (#70); Lou Vallario deposition (Exhibit A, at 67-69). Nor does HB 1224 contain any exemption allowing common carriers to transport such magazines to Colorado stores for sale in Colorado.

174. HB 1224 does not appear to allow Sheriffs to acquire magazines for purely personal use. There is an exemption in HB 1224 for:

(b) An employee of any of the following agencies who bears a firearm in the course of his or her official duties:

(I) a branch of the armed forces of the United States; or

(II) a department, agency, or political subdivision of the State of Colorado, or of any other state, or of the United States government.

If the exemption means that such persons may acquire magazines for personal use, then every private at Fort Carson can acquire personal magazines without limit and without need for authorization from a superior officer. Conversely, if the exception is read narrowly, to apply only to magazines for use in official duties, then the Sheriffs are currently prohibited from acquiring magazines for all of their firearms, except for the handguns that they carry on duty, and the long guns they keep in their official vehicles.

175. Any banned magazine which a Sheriff acquires after July 1, 2013, will instantly become criminal contraband on the day that the Sheriff retires from law enforcement. This is because the Sheriff will no longer qualify for the government employee exemption, and because grandfathering only applies to

magazines which were owned before July 1, 2013. The Sheriffs wish to retain such magazines for personal use after retirement.

176. HB 1224 includes a section punishing anyone who “sells, transfers, or possesses.” The section exempts many government employees. C.R.S. § 18-12-302(1)(a), (3)(b)(II). HB 1224 contains a separate section mandating that “A large-capacity magazine that is manufactured in Colorado” must have a date stamp. The section provides criminal penalties for violations. There is no government employee exemption. C.R.S. § 18-12-303. Some Sheriffs add extenders to their magazines, thus “manufacturing” a magazine which can accept more than 15 rounds. See, e.g., Exhibit A at 7-8, 11, 15, 46-47, 52-54; MERRIAM-WEBSTER.COM (“manufacture” definition 3, “the act or process of producing something”), <http://www.merriam-webster.com/dictionary/manufacture>; OXFORD ENGLISH DICTIONARY (“manufacture” defn. 2a, “to work up as or *convert into a specified product*”) (emphasis added).

#### **ii. Fifteen-round magazines**

177. Some Sheriffs, including Ronald Bruce, Jim Faull, Donald Krueger, Larry Kuntz, Sue Kurtz, Terry Maketa, Jerry Martin, Fred McKee, Brian Norton, Brett Powell, Ken Putnam, Justin Smith, Dennis Spruell, Lou Vallario, and Garrett Wiggins own one or more magazines with a nominal capacity of 15 rounds. They wish to be able to acquire such magazines in the future. As detailed in the expert report of Michael Shain, some nominally 15-round magazines are in fact “capable of accepting” 16 rounds; due to variations in manufacturing tolerances, some springs for 15-round magazines are so compressible that 16 rounds will fit in the magazine. Shain expert report at 11-12, Opinion B (#69, Exhibit B). This is confirmed by the

deposition of Defendant's witness Scott Wagner. (Filed as Exhibit C to this Amended Complaint, at 153-56, 192-95.) Defendant says he has no knowledge of this matter. Defendant's Response to Discovery from FFLs et al., at 23. (Attached to this Complaint as Exhibit D). (As previously stated, all exhibits to this Complaint are incorporated by reference.) Such magazines are outlawed by HB 1224 ("capable of accepting...more than fifteen rounds of ammunition"). Sheriffs Bruce, Kuntz, Maketa, Norton, Powell, and Wiggins own 15 round magazines which do in fact accept 16 rounds. (For Maketa, Exhibit A at 28.)

178. The very act of testing a 15-round magazine to see if it will accept 16 rounds instantly makes the magazine owner into a criminal in possession of contraband, if the magazine is discovered to accept 16 rounds. The mere possession of an untested 15 round magazine which actually could accept 16 rounds is also a crime. Accordingly, it is legally perilous to acquire a new a 15 round magazine. Magazines are often sold in circumstances which do allow the buyer to pretest the capacity. Moreover, stores which sell magazines have no way to test the capacity of every magazine prior to purchasing them at wholesale. (Shain report at 11-12, Opinion B [#69, exhibit B]; Wagner deposition at 177-78 [Ex. C. to this Complaint].) The Sheriffs wish to own such magazines, now and after they retire from law enforcement. They also wish to sell and/or temporarily transfer such magazines, on a short-term or long-term basis, to family members, friends, and other persons.

**iii. Sales and other transfers of personally-owned prohibited magazines**

179. Except for Sue Kurtz, all the Sheriffs wish to have the ability to make long-term loans of magazines to friends and family members. At present, Bruce Hartman, Fred Jobe, Terry Maketa, Jerry Martin, Bruce Newman, and Dave Stong currently have made, do make, or would make loans which are contrary to what is allowed by the Attorney General's July 10, 2013, "Technical Guidance" as interpreted by this Court. Donald Krueger would like to make such loans of his 17-round magazines after he retires in January 2015.

180. The Sheriffs wish to transfer ownership of their magazines either now or in the future, by sale, gift, and bequest. HB 1224 forbids such sales, gifts, and bequests for prohibited magazines. Under HB 1224, when a Sheriff dies, his magazines instantly become contraband, and HB 1224 immediately criminalizes whoever is the owner, custodian, or executor of the Sheriff's property.

181. All of the things that the Sheriffs wish to do with magazines of 16 rounds or more they also wish to do with magazines holding fewer than 16 rounds.

#### **iv. Sales and other transfers of firearms**

182. The Sheriffs wish to be able to sell, give, or lend handguns and long guns to persons of all races, ages, and nationalities, of both sexes (to persons who may lawfully possess such arms). The Sheriffs wish to make such sales, gifts, or loans under conditions that are unconstitutionally prohibited or restricted by HB 1224 and HB 1229. These include lending firearms for more than a 72 hour period, and giving firearms as gifts to persons who are not immediate family members. The Sheriffs further wish to be able to sell firearms to family members and to be able to



purchase firearms from family members; HB 1229's family exemption irrationally applies only to "bona fide gifts and loans," but not to sales.

183. HB 1229's requirement that temporary transfers of firearms—which are part of the ordinary use of a firearm—be treated as if they were gun sales violates the Second Amendment.

184. The dysfunctional system created by HB 1229 (requiring the use of a Federal Firearms Licensee [FFL], while capping the FFL's fee at \$10) often makes it extremely burdensome, and sometimes impossible, for law-abiding citizens, including the Sheriffs, to consummate a private sale or a temporary transfer.

**v. Prohibitions of firearms**

185. The Sheriffs wish to have the option, now as well as after they retire from law enforcement, of personally purchasing firearms for which there are no magazines which accept 15 or fewer rounds. These firearms include full-size Springfield Armory XD handguns in 9mm and .40 caliber, the Kel-Tec PMR .22 caliber pistol, and the SRM Arms model 1216 shotgun (a pump action shotgun with four tubes that each hold four rounds). Without a magazine, none of these firearms are functional. Accordingly, HB 1224 amounts to a prohibition on such arms. Defendant admits that there are no commercially available magazines for the Springfield Armory and Keltec pistols. Defendant's Answers to Discovery from Sheriffs and Strumillo, at 9-10, interrog. 12 (Exhibit E to this Complaint.). There is self-evidently no alternative magazine for the SRM shotgun, since the magazine is integral to the shotgun.

186. Defendant asserts that such firearms are not de facto prohibited because an individual can “permanently alter” the magazines for these firearms. Defendant’s Answers to Discovery from FFLs et al., at 21-22 (Exhibit D to this Complaint); HB 1224 (“permanently altered so that it cannot accommodate more than fifteen rounds of ammunition”). This is incorrect. Notably, the possession of such a magazine, prior to alteration, is a crime. HB 1224 has no exemption for banned magazines which a person intends to alter. Further, according to Defendant’s witness Scott Wagner, every method for limiting the capacity of a magazine can be undone in no more than a half hour, and more typically in just “a matter of minutes” or “a couple minutes.” Scott Wagner deposition at 171-77, 187-89. (Exhibit C to this Complaint.) Finally, Defendant refuses to say whether a common means of attaching a limiter—with a pin—does or does not count at a permanent alteration. Defendant’s Answers to Sheriffs and Strumillo Discovery, at 6, interrog. 7 (Exhibit E to this Complaint).

**d. Sheriffs’ inability to comply with HB 1224 and 1229**

187. The Sheriffs, like the other Plaintiffs, wish to know how to comply with HB 1224 and 1229. During the discovery process, it has become clear that when citizens have questions about how to comply with HB 1224 or HB 1229, the Colorado Bureau of Investigation refers such questions to the Attorney General. The Attorney General then refuses to answer, or refers the citizens back to the Colorado Bureau of Investigation. The citizen may be sent copies of Defendant’s signing statement, and of the Attorney General’s two Technical Guidance letters.

See CBI document production at CBI 00031-33, CBI 00071, CBI 00074-75, CBI 000124-26 (attached to this Complaint as Exhibit F); CBI Director Ronald Sloan deposition at 55-58 (attached to this Complaint as Exhibit G) (CBI will only answer citizen questions for which the black letter law answer is obvious).

188. There are many questions about how to comply with HB 1224 and 1229 which are in no way addressed by Defendant's signing statement or by the Technical Guidance. Indeed, these documents do not even address HB 1229. Regarding HB 1224, they only address two particular issues ("designed to be readily converted" and "continuous possession.") During discovery, the Plaintiffs asked Defendant various questions about the meaning of HB 1224 and HB 1229. Defendant refused to answer. Regardless of whether some or any of Defendant's refusals might be sanctionable, the refusals underscore the fact that *no-one* in the Colorado State government can or will provide citizens with answers about how citizens, including the Sheriffs, are supposed to comply HB 1224 and 1229. Among the issues for which there is no answer are the following, all of which are taken verbatim from Plaintiffs' discovery requests to Defendant:

- If an individual privately transfers a firearm to another individual, and a background check is performed pursuant to HB 1229, would you consider that background check sufficient to cover any subsequent transfers of the same firearm between the same two individuals?
- If an employer loans an employee a firearm for more than 72 hours and conducts the necessary background check pursuant to HB 1229, would you

require the employee to conduct another background check upon returning the firearm to his or her employer?

- Please describe the process for conducting a background check under HB 1229 when the transferee of the firearm is not a natural person, such as a limited liability company or corporation.
- If a farm or ranch employee utilizes a vehicle owned by his or her employer for more than 72 hours, and the vehicle contains a firearm, do you interpret HB 1229 to require a background check to be performed on the employee even if he or she never touches the firearm?
- Admit that with respect to HB 1229 there is no exception for farmers or ranchers who, for a period of more than 72 hours, loan firearms to employees for defense of livestock and crops.
- Admit that there is no exemption in HB 1229 for firearms training conducted under the auspices of a nonprofit organization other than at a shooting range under C.R.S. § 18-12-112(6)(e)(I).
- Admit that no licensed gun dealer in Colorado is required to perform a background check when requested to do so by two individuals conducting a private sale or transfer of a firearm.
- What recourse does a person have under HB 1229 or any other laws of the State of Colorado if he or she wants to transfer a firearm but cannot find a Federal Firearms Licensee (“FFL”) either available or willing to perform the required background check?

- Admit that HB 1224's exceptions pertaining to lawful possession of banned magazines after July 1, 2013, do not include any provision allowing retailers to possess banned magazines for the purposes of selling such magazines to law enforcement officers within Colorado.
- Admit that HB 1229 contains no exception pertaining to the permanent acquisition of firearms by law enforcement officers for law enforcement purposes.
- Admit that HB 1229 contains no exception pertaining to the temporary acquisition of firearms by law enforcement officers for law enforcement purposes.
- Admit that HB 1229 forbids the return of a stolen firearm to the rightful owner, unless the return is processed by a FFL pursuant to HB 1229's requirement for background check and for FFL record-keeping.
- Admit that HB 1229 forbids law enforcement officers from taking a citizen's firearm for temporary safe-keeping for more than 72 hours, unless the transfer is processed by a FFL pursuant to HB 1229's requirement for background check and for FFL record-keeping. By way of illustration, this question includes a situation in which a citizen is the victim of a crime or accident, is therefore unconscious, and is therefore unable to safeguard a firearm which the citizen was carrying or transporting.

- Admit that HB 1224 contains no exemption for long-haul truckers transporting banned magazines from another state through Colorado for delivery to another state.
- Admit that HB 1224 contains no exception for travelers passing through Colorado who possess a banned magazine which was acquired on or after July 1, 2013.

See Defendant's Second Answer to Discovery from Non-Profits and Disabled Individuals, at 3-6; Defendant's First Answer to Discovery from Non-Profits and Disabled Individuals, interrog. 10; Defendant's Answer to Discovery from Sheriffs and David Strumillo at 10-13) (Exhibits H, I & E to this Complaint). Most of these unanswered, unknown vagaries of HB 1224 and 1229 relate to infringements of the Sheriffs' personal ability to personally acquire, transfer, and use magazines and firearms—on-duty, off-duty, or after retirement; or to the personal decisions that Sheriffs must make regarding firearms and magazines that they personally handle in the course of their employment.

## **2. Colorado Farm Bureau**

189. Colorado Farm Bureau is a Colorado nonprofit corporation. It was founded in 1919 by a group of Colorado farmers, ranchers, veterinarians, rural doctors, shopkeepers and tradesmen. The Farm Bureau's mission includes enhancing Colorado's agricultural industry; promoting, protecting, and representing the interests of farmers, ranchers, and their communities; and protecting individual freedom and opportunity.

190. Colorado Farm Bureau's membership now comprises 23,000 Coloradans, including Colorado farmers, ranchers, and other Colorado families and residents who have an interest in maintaining a strong agricultural industry in this State and in promoting and advancing the interests of Colorado farmers and ranchers.

191. Section (1)(b) of HB 1229 requires that if a transferee of a firearm is not a natural person, "then each natural person who is authorized by the transferee to possess the firearm after the transfer shall undergo a background check . . . before taking possession of the firearm."

192. The vast majority of Colorado farms, including family farms, operate as incorporated businesses. Thus, when most Colorado farmers acquire firearms in connection with their farming or ranching operations, they do not acquire them as "natural persons."

193. Colorado farmers and ranchers often operate their businesses in rural and remote areas of the State. Firearms are a necessity for farming and ranching for protecting crops and livestock, as well as for self-defense.

194. HB 1229 places substantial burdens on the Second Amendment rights of Colorado farmers and ranchers because:

a. it will often be very difficult to identify each and every natural person associated with the farm or ranch who may possess the firearm;

b. it will be very difficult to find FFLs able and willing to perform the necessary checks in many, if not most, of the rural areas in which farms and ranches are located;

c. even when FFLs are available, able, and willing to perform the necessary checks, paying a fee for each check for each natural person who may possess a firearm places a significant financial burden on the farm or ranch acquiring the firearm.

195. Setting aside problems with initial acquisitions of firearms, HB 1229 places an enormous burden on farmers and ranchers to police firearm possession as time passes. If farms or ranches do not routinely “audit” new farm and ranch hands, they face significant criminal exposure (and being prohibited from owning any firearm for at least two years) if a new hand obtains possession without a check being performed first, as well as joint and several civil liability if an accident or misuse involving the firearm occurs.

### **3. Firearms Industry Trade Association**

196. The National Shooting Sports Foundation (“NSSF”) is a national trade association for the firearms, ammunition, and hunting and shooting sports industry based in Newtown, Connecticut.

197. As a non-profit, tax-exempt corporation, NSSF has a membership of over 9,500 federally licensed firearms manufacturers, distributors and retailers; companies manufacturing, distributing and selling shooting and hunting related goods and services; sportsmen’s organizations; public and private shooting ranges; gun clubs;



publishers and individuals. More than 300 of these members reside and conduct business in Colorado.

198. The NSSF's members in Colorado provide lawful commerce in firearms to law-abiding Coloradans. Each of these members' business interests and livelihoods will be adversely and unconstitutionally affected by HB 1224 and HB 1229.

#### **4. Retired Law Enforcement Officers**

199. David Strumillo resides in Colorado Springs, Colorado, and is a citizen of the United States. Mr. Strumillo served as a police officer in the Parker, Colorado Police Department from 1994 through 1999, when he was medically retired following an injury in the line of duty.

200. Mr. Strumillo is authorized to carry a concealed firearm in all states and U.S. territories pursuant to the Law Enforcement Officers Safety Act, 18 U.S.C. § 926B, 926C. In order to comply with federal law, Mr. Strumillo is required to re-qualify each year using the firearms he carries.

201. Mr. Strumillo also carries firearms for his personal safety to respond to threats made against himself and his family. The firearms Mr. Strumillo carries use magazines larger than 15 rounds. The members of the Plaintiff Associations also include retired law enforcement officers.

#### **5. Disabled Citizens**

202. David Bayne is a resident of Thornton, Colorado, and a citizen of the United States. Mr. Bayne is paralyzed from the chest down and confined to a

wheelchair. He holds a concealed carry permit issued by the Adams County Sheriff's Office, which is valid in the State of Colorado. He owns several firearms, several of which accept magazines capable of holding more than 15 rounds. Mr. Bayne uses these firearms for target shooting, shooting competitions, and the defense of his home.

203. Dylan Harrell is a resident of Frederick, Colorado, and a citizen of the United States. Mr. Harrell is paralyzed from the chest down and confined to a wheelchair. He holds a concealed carry permit issued by the Adams County Sheriff's Office, which is valid in the State of Colorado. He owns several firearms which will accept magazines capable of holding more than 15 rounds. He uses these firearms for hunting, target shooting, and defense of his home.

204. Messrs. Bayne and Harrell ("the Disabled Plaintiffs") are deprived of their fundamental right of self-defense in multiple ways.

205. First, because firearms that use magazines larger than 15 rounds and those with removable floor plates or end caps are in common use, their Second Amendment right to self-defense pursuant to *Heller* is violated regardless of any disability because they may be unable to purchase replacement magazines of any size, and particularly of the standard 30-round size, which are essential to a disabled person.

206. Second, disabilities make it difficult to quickly change magazines under the stress of a home invasion. For example, Plaintiff Dylan Harrell is wheelchair bound and has two small children in his home. The wheelchair limits

Mr. Harrell's mobility and severely restricts his ability to quickly place himself in the best position to repel a home invasion, as well as his ability to place himself behind barriers or use objects in his home as a means to steady his firearm. Thus, he is even more dependent on immediate firearms defense than able-bodied people, who might be able to flee the house or buy time by running to another room. The limits on Mr. Harrell's ability to quickly re-position himself also severely limit his ability to retreat quickly and effectively in order to allow him the time necessary to change magazines. Eliminating his ability to use magazines with a capacity larger than 15 rounds has a corresponding impact on his ability to exercise his constitutional right to defend himself, his home, and his children.

207. Like Mr. Harrell, Plaintiff David Bayne is confined to a wheelchair and faces the same challenges. Mr. Bayne has limited ability to retreat or re-position himself effectively or safely during a home invasion in order to most effectively aim and discharge his firearm, or to safely change magazines.

208. If the ban on smaller magazines that can be readily converted is not a total prohibition, but applies only after a determination of the intent of the designer, the Disabled Plaintiffs have no ability to resolve that ambiguity and cannot discern what magazines are allowed and what magazines may subject them to criminal penalties.

## **6. Licensed Firearms Dealers**

209. USA Liberty Arms is a Colorado corporation with its principal place of business in Fort Collins, Colorado.

210. Rocky Mountain Shooters Supply is a Colorado corporation with its principal place of business in Fort Collins, Colorado.

211. 2nd Amendment Gunsmith & Shooter Supply, LLC (“2nd Amendment”), is a Colorado corporation with its principal place of business in Loveland, Colorado. 2nd Amendment has expended significant resources on inventory in firearms and magazines that will be rendered illegal on July 1, 2013. 2nd Amendment will suffer significant losses in its overall sales if it cannot sell firearms or magazines over 15 rounds or with removable floor plates or end caps if HB 1224 becomes effective.

212. Burrud Arms Inc. d/b/a Jensen Arms is a Colorado corporation with its principal place of business in Loveland, Colorado. Jensen Arms is a retail firearms dealer in business since 1994 that serves customers throughout much of Colorado. To serve its customers, Jensen Arms has invested millions of dollars in magazines and firearms inventory that utilizes magazines that will be prohibited under HB 1224. Customers have already expressed confusion about what magazines will be legal, and Jensen Arms will suffer significant losses in sales.

213. Green Mountain Guns is a Colorado corporation with its principal place of business in Lakewood, Colorado. Green Mountain Guns has been in business for 35 years, and will lose approximately \$2 million in sales after HB 1224 becomes effective because the majority of firearms and magazines that it sells will be rendered illegal on July 1, 2013, including many smaller magazines that have removable floor plates or end caps.

214. Smith & Wesson has already informed Green Mountain Guns that it will no longer ship merchandise to Green Mountain Guns because of the uncertainty caused by HB 1224 and confusion about what firearms and firearm accessories will be illegal after HB 1224 goes into effect.

215. Jerry's Outdoor Sports is a Colorado corporation with its principal place of business in Grand Junction, Colorado. Jerry's Outdoor Sports has been in business for 28 years, and will lose the majority of its sales if HB 1224 becomes effective because the majority of firearms and magazines that it sells will be rendered illegal on July 1, 2013, including many smaller magazines that have removable floor plates or end caps.

216. Grand Prix Guns is a Colorado corporation with its principal place of business in Littleton, Colorado. Grand Prix Guns anticipates that it may suffer as much as an 80% loss in revenue if HB 1224 renders the majority of the firearms and magazines it sells illegal.

217. Specialty Sports & Supply is a Colorado corporation with its principal place of business in Colorado Springs, Colorado. Specialty Sports & Supply anticipates that it will lose more than \$1 million annually in firearms sales. The store currently has 4,000 to 5,000 magazines in stock which it will not be able to sell after July 1, 2013, and it will be unable to order and sell additional supplies.

218. Goods for the Woods is a Colorado corporation with its principal place of business in Durango, Colorado. Goods for the Woods has a current inventory of

firearms and magazines that will be rendered illegal as of July 1, 2013, and it will also be unable to sell existing and future orders, significantly reducing revenue.

219. The Plaintiff firearms dealers have invested significant money in existing inventories of firearms with standard magazines larger than 15 rounds and in magazines of all sizes with removable floor plates and end caps. That investment will be lost without compensation if that inventory cannot be sold. In some cases, the continued existence of the business may be threatened.

220. The licensed dealers face the same conundrum as all Plaintiffs if they are forced to guess at the unknown intent of designers of smaller magazines, and are subject to the whims of local law enforcement as they try to enforce an ambiguous statute.

221. In addition, in light of the fee caps described in Paragraph 21 above, each of the Licensed Firearms Dealers will be unwilling or financially unable to provide the services necessary for transfers under HB 1229, making compliance with HB 1229 impossible in many private transfer situations.

## **7. Shooting Association and Shooting Ranges and Clubs**

222. The Colorado State Shooting Association (“CSSA”) is the oldest statewide shooting and firearms organization in Colorado, established in 1926.

223. CSSA has nearly 1,500 individual dues-paying members, and over 20 business and club members that collectively add more than 20,000 associated members. These members include hunters, competitive shooters, recreational shooters, firearms instructors, active and retired law enforcement officers, crime

prevention advocates, firearms and equipment dealers and wholesalers, and people interested in preserving Second Amendment rights. The membership includes many who have physical disabilities.

224. Many CSSA members own and use firearms with a capacity exceeding 15 rounds, and many of the CSSA sanctioned events require the use of such firearms. Many CSSA members also own magazines (and associated firearms) with removable floor plates or end caps.

225. The CSSA provides shooting opportunities for law-abiding Colorado residents by uniting shooters, hunters, sportsmen and collectors, as well as all other types of law-abiding firearms enthusiasts, to promote the safe and responsible use of firearms.

226. CSSA promotes the development of shooting sports and related facilities and speaks on behalf of its membership to defend shooting sports, hunting rights, and firearms ownership.

227. CSSA also promotes and organizes firearms safety programs and hunter safety education, supports the training of NRA-certified firearms instructors, and organizes and supports state regional competitive matches.

228. CSSA is the official NRA-delegated sanctioning body for all state and regional competitive firearms matches in Colorado, and CSSA membership is required for Colorado shooters to participate in any such matches. CSSA is also the official state association for the Civilian Marksmanship Program, a congressionally-

created program that fosters firearms marksmanship through competitive matches and clinics.

229. The members of the Colorado State Shooting Association engage in every form of lawful activity with firearms and magazines, including each and every activity mentioned in this Complaint.

230. Hamilton Family Enterprises, Inc. d/b/a Family Shooting Center at Cherry Creek State Park (“FSC”) is a Colorado corporation that is designated as the Cherry Creek State Park concessionaire for operating recreational shooting facilities located at the Cherry Creek State Park in Arapahoe County, Colorado.

231. FSC is a multi-discipline shooting facility covering approximately 120 acres of Cherry Creek State Park and includes a rifle range, a pistol range, a law-enforcement range, a sporting clays and five-stand range, a trap range using both electric and hand launching stations, a shotgun patterning board, and an archery range. FSC is currently adding a “move-and-shoot” pistol range which will double the number of pistol shooting positions available to the public.

232. FSC is the largest public outdoor shooting facility on the Front Range in Colorado. The usage of these facilities has increased each year since FSC began concession operations in 2004, and over 64,000 shooters used the facilities at FSC in 2012.

233. In addition to the operation, supervision and maintenance of the shooting facilities at Cherry Creek State Park, FSC also makes available for use by qualified members of the public firearms that are equipped with standard



magazines having capacities of more than 15 rounds or are equipped with smaller magazines that are readily convertible to more than 15 rounds.

234. Moreover, FSC sells firearms equipment and accessories, which include magazines with capacities exceeding 15 rounds or are otherwise readily-convertible to more than 15 rounds.

235. Approximately fifty percent of FSC's gross revenue currently derives from the sale of firearms equipment, accessories, and ammunition.

236. FSC's patrons have already expressed concerns over the impact that HB 1224 and HB 1229 will have on their ability to legally utilize FSC's facilities or purchase goods and equipment from FSC, and many have signified their intent that they will not return to FSC after July 1, 2013 for fear of running afoul of the new laws. Thus, both proposed laws have already adversely impacted FSC's business and income and will continue to do so in the future.

237. Approximately six percent of all of FSC's revenue, not including Colorado sales taxes, are remitted to the State and Colorado's state park system. The significant and inevitable decline in revenue that will result from the implementation of HB 1224 and HB 1229 will significantly impact the already handicapped budget of Colorado's state park system.

## **8. Firearms Accessories Manufacturer**

238. Plaintiff Magpul Industries is a Colorado corporation founded in 1999 with its principal place of business in Erie, Colorado. Magpul manufactures and

sells a wide variety of firearms accessories, including firearm magazines in a variety of sizes.

239. Magpul has approximately 200 employees in Colorado, and approximately 90% of its magazine suppliers are located in Colorado. Magpul will be unable to distribute magazines with capacities more than 15 rounds to its network of Colorado retailers and faces uncertainty as to whether it can continue to distribute any magazines to Colorado retailers based on the vague provisions of HB 1224.

240. Magpul manufactures magazines in 10, 20, and 30 round sizes for sale to the public. Magpul has existing commitments to sell magazines through its distribution network to retailers in Colorado. Magpul may have to modify those commitments for magazines larger than 15 rounds, and lose the value of those sales.

241. For magazines smaller than 15 rounds, Magpul faces the same uncertainty as all of the Plaintiffs in determining which, if any, magazines with a removable floor plate can be sold. If all smaller magazines with removable floor plates are banned by HB 1224, then Magpul effectively cannot sell any magazines in Colorado.

242. If the prohibition of smaller magazines is resolved only by law enforcement's interpretation of each designer's intent, Magpul cannot predict how each of the Colorado law enforcement jurisdictions will resolve the ambiguity in the statute, and faces the uncertain prospect of criminal prosecution in jurisdictions

that interpret the statute as a complete ban on magazines with a removable floor plate.

## **9. Nonprofit Representing Disabled Outdoor Enthusiasts**

243. Outdoor Buddies, Inc. (“Outdoor Buddies”), which was founded in 1984, is an all-volunteer non-profit organization based in Colorado. Its mission is to provide opportunities to enjoy the outdoors to those who have been deprived of it, regardless of race, creed, religion, or sex, and with no fees to the participant. Outdoor experiences provided through Outdoor Buddies include hunting, target shooting, fishing, boating, camping, and education in the use of the outdoors for recreational activities.

244. There are approximately 760 individual members of Outdoor Buddies. Approximately two-thirds of the membership is composed of mobility-disabled members of the community who need special assistance to experience the outdoors. Approximately one-third of the membership is composed of able-bodied members of the community who serve as volunteers. The membership includes many wounded warriors and other disabled veterans from World War II through the most recent military conflicts in Iraq and Afghanistan.

245. The Disabled Plaintiffs, David Bayne and Dylan Harrell, are members of Outdoor Buddies.

## **10. Nonprofit Representing Colorado’s Outfitters**

246. The Colorado Outfitters Association is an organization dedicated to improving the Colorado outfitting industry’s standards and the quality of services

provided by professional outfitters in Colorado. The Association represents approximately 790 professional hunting, fishing, and camping outfitters and guides based in Colorado. Colorado's outfitters are registered, bonded, and insured to operate in Colorado and have permits to operate on public lands. The Association represents Colorado's outfitters in a wide range of policy areas affecting Colorado outfitters and their clients.

247. The chilling effect of the potential legal perils for non-resident hunters caused by HB 1224 and 1229 has led many non-resident hunters to shun Colorado, which will cost the outfitters, local businesses which cater to hunters (e.g., restaurants and stores), the State, and various local taxing jurisdictions tens of millions of dollars in the next few years. Moreover, HB 1229's requirements for background checks for transfers could significantly impact the ability of outfitters and their clients to share weapons in the field given the narrowness of HB 1229's exceptions and the unavailability of FFL's to perform the necessary background checks.

## **11. Nonprofit Representing Women's Right to Self-Defense**

248. Women for Concealed Carry is a 26 U.S.C. § 501(c)(4) nonprofit organization registered in the State of Colorado. Women for Concealed Carry supports women's rights to effective self-defense against physical harm by protecting women's rights to carry concealed firearms, and the organization conducts outreach and education to support policies that defend that right.

Members of the organization use and carry magazines which would be banned under HB 1224.

## **12. Nonprofit Representing Colorado Families and Communities**

249. Colorado Youth Outdoors (“CYO”) is a nonprofit organization whose mission is to serve Colorado communities by providing families with opportunities to build healthy relationships through traditional outdoor recreation. One of the many disciplines in CYO’s program is shooting sports.

250. As part of its programming, CYO provides a curriculum for firearm safety, as well as a program to introduce families to sport shooting, including wildlife management through hunting. These programs stress the lawful, responsible and safe use of firearms.

251. Fundraising is an extremely important aspect of CYO’s ongoing mission to serve Colorado communities and families. Its most successful fundraiser each year is a weekend event involving target shooting.

252. Because most of the participants in CYO’s programs are new to shooting sports, CYO frequently loans hunting and sporting firearms to participants, sometimes for periods exceeding 72 hours. HB 1229 will render this aspect of CYO’s programming illegal. Similarly, CYO loans firearms to participants at its annual fundraiser, which is held at a for-profit “dude ranch” specializing in hosting private events. HB 1229 will have a significant impact on this important fundraiser and consequently on CYO’s ability to pursue its mission.

253. CYO makes additional firearm loans to other qualified non-profits who do not have the resources to own firearms but who occasionally have special programs or events requiring the use of firearms. These loans sometimes exceed 72 hours. Loaning resources and collaboration between non-profits is critical in non-profit business operations.

254. Constraining laws with narrowing margins for lawful use make it more difficult to find qualified board members willing to navigate through vague and uncertain firearm legislation. HB 1229 adds another burden to those in leadership roles of organizations which own firearms, which will have devastating effects on CYO's board membership.

## **B. Defendant**

255. Defendant John Hickenlooper is the Governor of the State of Colorado, and is required to ensure that all laws of the state are faithfully executed. COLO. CONST. art. IV § 2. As Colorado's Chief Executive, Governor Hickenlooper is the proper defendant to actions to enjoin or invalidate a state statute. *Developmental Pathways v. Ritter*, 178 P.3d 524, 529 (Colo. 2008).

## **IV. ADDITIONAL SUPPORT FOR ALLEGATIONS**

### **A. The Restrictions on Firearms Use in the Bills Is Greater Than That Already Determined to Violate the Second Amendment**

256. The effects of these bills on commonly-used firearms are far more overreaching than laws in other locations that have already been determined to be

unconstitutional. In *District of Columbia v. Heller*, the Supreme Court addressed a prohibition on the possession of handguns in the District of Columbia.

257. Significantly for this case, the *Heller* Court concluded that the “inherent right of self-defense has been central to the Second Amendment right.” 554 U.S. at 628.

258. The individual right to keep and bear arms and to use those arms for self-defense extends to all firearms that are “in common use at the time.” *Id.* at 627. The Court emphasized that the Second Amendment does protect firearms which are “typically possessed by law-abiding citizens for lawful purposes.” Firearms which do not meet this standard may be banned if they are “dangerous and unusual weapons.” The paradigmatic examples of the latter category are sawed-off shotguns and machine guns. *Id.* at 625, 627.

259. The Court noted that like all constitutional rights, the Second Amendment is not absolute in every respect. The Court described three particular types of gun controls as “presumptively constitutional”: First, the long-standing prohibitions against possession of firearms by felons and the mentally ill. Second, laws forbidding the carrying of firearms in “sensitive places such as schools and government buildings.” Third, “laws imposing conditions and qualifications on the **commercial** sale of firearms.” *Id.* at 626-27 (emphasis added).

260. HB 1224 and 1229 do not fit within any of the “presumptively constitutional” gun control categories described by the *Heller* Court. The bills do not amend Colorado’s long-standing laws forbidding gun possession by various

categories of persons who have proven themselves to be dangerous. They do not affect the carrying of guns in “sensitive places.” They do not set “conditions or qualifications” on the “commercial sale” of arms. HB 1229 applies only to non-commercial transfers, and to short term-transfers which do not involve any type of sale.

261. In *McDonald v. Chicago*, the Supreme Court addressed a ban similar to that in *Heller* that was in place in Chicago and the suburb of Oak Park. The *McDonald* Court held that the Second Amendment right enunciated in *Heller* applies with equal force to the States through the Fourteenth Amendment.

262. The *McDonald* Court reiterated that the right to self-defense is “deeply rooted in this nation’s history and tradition,” and that the “ratifiers of the Fourteenth Amendment counted the right to keep and bear arms among those fundamental rights necessary to our system of ordered liberty.” 130 S. Ct. at 3036, 3042. The *McDonald* Court reiterated the holding in *Heller* that “the Second Amendment protects a personal right to keep and bear arms for lawful purposes, most notably for self-defense within the home,” and held that “the Fourteenth Amendment incorporates the Second Amendment right recognized in *Heller*.” *Id.* at 3044, 3050.

263. By outlawing the larger and smaller magazines which are necessary components of the large majority of handguns and of a very large number of rifles, HB 1224 is a gun ban even more sweeping than the handgun-only ban which was ruled unconstitutional in *Heller*.



264. The *Heller* Court pointed out that the D.C. handgun ban was “a prohibition of an entire class of ‘arms’ that is overwhelmingly chosen by American society for that lawful purpose” of self-defense. 554 U.S. at 628. The prohibition was so facially unconstitutional that the *Heller* Court found it unnecessary to use the traditional three-tiered system of scrutiny. Responding to Justice Breyer’s attempt to apply a balancing test to the D.C. ban, the *Heller* Court stated that the handgun ban failed “any of the standards of scrutiny the Court has applied to enumerated constitutional rights.” 554 U.S. at 571. Thus, the handgun ban would have failed both strict scrutiny and intermediate scrutiny, and the result was so obvious that the *Heller* Court did not need to discuss the prongs of the two tests.

265. The HB 1224 ban on most handguns and many rifles (accomplished by banning the large majority of magazines) is thus even more obviously unconstitutional.

266. Magazines of 16-20 rounds for handguns, and 16-30 rounds for rifles, easily satisfy the “common use” and “typically possessed” standards in *Heller*. Under *Heller*, their prohibition is thus *per se* unconstitutional. The Constitution is clear, and the balancing has already been done by the enactment of the Second and Fourteenth Amendments themselves. Firearms and accessories which are typically owned by law-abiding citizens for lawful purposes may not be prohibited.

267. Even if it were proper to apply strict or intermediate scrutiny (which it is not), the fact that a handgun ban cannot even pass intermediate scrutiny resolves the instant case. Handguns are used in the majority of homicides in the United

States, and in over two hundred thousand violent crimes annually. The number of crimes (including multiple victim homicides) in which handguns are used dwarfs the number of such crimes involving magazines that hold more than 15 rounds. Because a handgun ban cannot survive intermediate scrutiny, the HB 1224 magazine ban cannot survive strict scrutiny.

268. The banned magazines and associated firearms are also lawful in Colorado for hunting. While many states specify no magazine limitations for hunting, Colorado is among the group that has some limitations. These are as follows: Rifles or handguns of any type for small game, no limit; centerfire semi-automatic rifles for big game, six rounds; centerfire rifles of other types (e.g., bolt action, pump action, lever action) for big game, no limit; handguns for big game, no limit; shotguns for migratory bird hunting, three rounds – otherwise, no limit.

269. Regardless of limits while in the field, hunters at their hunting camp in isolated areas, or who are driving to or from a hunting trip, may wish to have a fully functioning defensive firearm with a fully loaded magazine. This defensive arm might be their hunting gun, or it might be another firearm.

270. In certain types of big game hunting (e.g., elk or deer) it would be rare for a hunter to get more than two shots at an animal. In other types of hunting (e.g., prairie dogs or a pack of coyotes) a significant number of consecutive shots at different animals in a group would be common. When Colorado hunters take their guns and magazines to go hunting in other states (as many Plaintiffs do, especially the members of the Colorado Outfitters Association and the members of the

Colorado State Shooting Association), hunters may fire a significant number of quick shots at game such as wild boars, which are notoriously hardy and ferocious. Even the big game hunter who only plans one or two shots for the trophy deer may want a firearm with larger capacity in case of attack by bears, mountain lions, other large predators, or criminals.

271. The requirement of “continuous possession” for grandfathered magazines prevents owners of affected firearms from engaging in safety training, repair, temporary loans for sporting purposes, and temporary loans for lawful self-defense. This self-defense prohibition flatly contradicts *Heller* and *McDonald*.

272. The ban on repair and the crippling of defensive instruction violates *McDonald*, which quoted with approval the Tennessee case of *Andrews v. State*, 50 Tenn. 165 (1871), which in turn affirmed that the right to keep and bear arms includes the right to have firearms repaired and to practice their safe use. A law which impedes safe instruction and practice in the use of firearms (as HB 1224 and HB 1229 do) is subject to a heightened level of scrutiny which the Defendant cannot meet in this case. *See Ezell v. Chicago*, 651 F.3d 684, 708 (7th Cir. 2011) (enjoining municipal ban on gun ranges, the use of which are ancillary to the exercise of core Second Amendment rights).

273. HB 1224 is facially unconstitutional as a ban on common arms and accessories and as a ban on temporary transfers for self-defense.

274. Putting aside the facial unconstitutionality, if heightened scrutiny were to be applied, HB 1224 does not serve any legitimate governmental purpose,

let alone the “important” or “compelling” purpose which is necessary under heightened scrutiny. To the contrary, the chief House sponsor and the chief Senate sponsor of HB 1224 both stated, repeatedly, that the “only” purpose of magazines of more than 15 rounds was to kill a large number of people quickly. The fact that tens of millions of such magazines are owned by peaceable citizens – and that such magazines are chosen by many of the Plaintiff Sheriffs and their Deputies for saving lives and for the lawful defense of self and others – demonstrates beyond any doubt the falsity of the sponsors’ assertions.

275. Based on the statements of the sponsors themselves, HB 1224 is the product of animus – the invidious prejudice that is the quintessence of an *illegitimate* purpose. *Romer v. Evans*, 517 U.S. 620 (1996); *Lawrence v. Texas*, 539 U.S. 558 (2003).

276. HB 1224’s ban on the very magazines which a vast number of Sheriffs, other law enforcement, and law-abiding citizens choose as the best tools for the lawful defense of self and others substantially harms public safety. The ban is therefore the opposite of a “necessary” or “substantial” relation to enhancing public safety.

277. HB 1229 is unconstitutionally overbroad. The 1971 Colorado Supreme Court case *City of Lakewood v. Pillow*, 501 P.2d 744 (Colo. 1972), addressed a similarly sweeping gun control ordinance. Citing United States Supreme Court precedent, the *Pillow* Court held that a law is unconstitutional if there are “activities . . . entirely free of any criminal culpability yet the ordinance in question

effectively includes them within its prohibitions.” 501 P.2d at 745 (citing *Shuttlesworth v. Birmingham*, 382 U.S. 87 (1965); *Winters v. New York*, 333 U.S. 507 (1948)).

278. Under *Pillow*: “A governmental purpose to control or prevent certain activities, which may be constitutionally subject to state or municipal regulation under the police power, may not be achieved by means which sweep unnecessarily broadly and thereby invade the area of protected freedoms.” *Id.* at 745 (citing *Zwickler v. Koota*, 389 U.S. 241 (1967); *Aptheker v. Secretary of State*, 378 U.S. 500 (1963); *NAACP v. Alabama*, 377 U.S. 288 (1964)).

279. Moreover: “Even though the governmental purpose may be legitimate and substantial, that purpose cannot be pursued by means that broadly stifle fundamental personal liberties when the end can be more narrowly achieved.” *Id.* (citing *Aptheker*, 378 U.S. 500; *Shelton v. Tucker*, 364 U.S. 479 (1960)).

280. *Pillow* has been followed by several other courts, including in cases analyzing excessively intrusive gun control statutes. *E.g.*, *Benjamin v. Bailey*, 662 A.2d 1226, 1234 (Conn. 1995); *Junction City v. Mevis*, 601 P.2d 1145, 1150 (Kan. 1979); *State ex rel. City of Princeton v. Buckner*, 377 S.E.2d 139, 143 (W. Va. 1988).

281. If strict or intermediate scrutiny are applicable, Defendant must prove that HB 1224 and 1229 are “necessary” or have a “substantial” relation to a “compelling” or “important” government purpose. HB 1229, which in practice may be nearly impossible to comply with, has no necessary or substantial relation to anything. It bans temporary transfers for replacement guns for people whose guns

are being repaired for a week at the gunsmith, for hunters who go on a trip of more than 72 hours, for some persons who are being instructed in gun safety, and for some other persons who temporarily need guns for self-defense. This ban harms public safety rather than furthering it.

282. Sections 2-7 of HB 1229 contain various provisions for providing existing data to the FBI's National Instant Criminal Background Check System, and revisions of related laws. Section 2-7 is severable from Section 1 of HB 1229, which discusses private temporary transfers and private sales. Section 1 is void *in toto*. To be even arguably constitutional, Section 1 of HB 1229 would have to contain temporary transfer exceptions which were deliberately excluded from the bill and would also have to set up a functional system of background checks for private sales which private individuals could reasonably use. Such language might be created by the legislature, but cannot be created by a court. A law covering the same subject as Section 1 of HB 1229 might be constitutional in some applications, but Section 1 of HB 1229 as written is unconstitutional.

## **B. The Bills Are Unconstitutionally Vague**

283. The Due Process Clause of the Fourteenth Amendment prohibits statutes that are so vague that ordinary persons cannot readily determine whether their conduct might expose them to criminal penalties.

284. The long-established rule is that “the terms of a penal statute creating a new offense must be sufficiently explicit to inform those who are subject to it what conduct on their part will render them liable to its penalties is a well-recognized requirement . . . and a statute which either forbids or requires the doing of an act in

terms so vague that men of common intelligence must necessarily guess at its meaning and differ as to its application violates the first essential of due process of law.” *Connally v. General Const. Co.*, 269 U.S. 385, 391 (1926). What conduct is lawful cannot be left to conjecture. “The crime, and the elements constituting it, must be so clearly expressed that the ordinary person can intelligently choose, in advance, what course it is lawful for him to pursue.” *Id.* at 393.

285. A statute is also unconstitutionally vague if it may result in arbitrary enforcement based on the personal predilections of individual law enforcement officers or jurisdictions. Vague statutes are subject to particularly rigorous scrutiny when they impact the exercise of constitutional rights.

286. The “continuous possession” and “designed to be readily convertible” provisions of HB 1224 are both vague, and both severable.

287. Any contention that HB 1224’s ban on all magazines “designed to be readily converted” somehow does not prohibit smaller magazines with a removable floor plate or end cap only highlights the defects in the bill. HB 1224 provides no definition of “readily converted,” and the fact is that the large majority of magazines can be converted to hold more than 15 rounds.

288. Conversions to magazines using aftermarket extenders are particularly easy to accomplish. Ordinary gun owners cannot be expected to monitor the vast world of aftermarket products in order to know whether an extender is currently commercially available for their magazines.

289. If the “designed to be readily converted” language does not mean what the sponsor and the Governor said it did (a ban on all magazines with removable floor plates), the language is unconstitutionally vague. If the ban is somehow limited by the intent behind how the magazine was “designed,” then HB 1224 is unconstitutionally vague because citizens have no means to discern how a product was designed. Neither gun owners nor licensed firearms dealers nor law enforcement officers have a clear guide as to which small magazines are legal and which are not, and local law enforcement interpretations will inevitably vary.

290. HB 1224 is also vague in its ban on anything “capable of accepting . . . more than fifteen rounds of ammunition. Rifle cartridges of a particular diameter have varying lengths. For example, Uberti manufactures an exact replica of the 1875 Colt Lightning pump action rifle. The tube magazine will accept 13 rounds in .357 magnum caliber. Cartridges in .38 caliber a fully usable in .357 firearm; the same Uberti rifle will also accept 18 rounds of .38 Special wadcutter ammunition. An owner of this Uberti rifle might think that he has a legal 13-round magazine; but in fact, such a rifle could be illegal under HB 1224. The ordinary gun owner plaintiffs, as well as plaintiffs involved in the firearms business, cannot tell whether such rifles are legal to sell or transfer after July 1, 2003.

291. HB 1224’s unconstitutional requirement that a grandfathered magazine be in “continuous possession” of the owner mirrors similar language in HB 1229. Both bills had the same House of Representatives sponsor. HB 1229 exempts from the background check requirement “(g) any temporary transfer that



occurs while in the continuous presence of the owner of the firearm.” Obviously, this means that the owner of the firearm must be present at all times in the exact place where the transferee is holding the gun. The requirement of “continuous presence” would obviously not be satisfied if the owner left for half an hour or for a few days. Accordingly, “continuous possession” is likewise broken if it is interrupted for half an hour or for a few days.

292. For the reasons stated in paragraphs 13-14, this is a direct violation of the Second Amendment. If any argument is offered that “continuous possession” means something else, the argument demonstrates that “continuous possession” is void for vagueness.

293. Governor Hickenlooper, when signing HB 1224 and 1229, promised that “guidance” would be created for their implementation. Such “guidance” is not legally binding on all state and local law enforcement officers and prosecutors throughout Colorado. Nor can there be any assurance that “guidance” which is written in one year will not be changed in a future year. To the extent that the guidance suggests that law enforcement refrain from enforcing the actual statutory language of HB 1224 and 1229 in certain situations, the guidance would amount to an admission that the actual text of those bills is an unconstitutional infringement of Second or Fourteenth Amendment rights.

### **FIRST CLAIM FOR RELIEF**

#### **(HB 13-1224 – Violation of Second and Fourteenth Amendments Based on Prohibition of Magazines Larger Than 15 Rounds)**

294. Paragraphs 1 through 202 are re-alleged and incorporated herein.

295. HB 1224 was signed by Governor Hickenlooper on March 20, 2013. It explicitly prohibits all magazines with a capacity of larger than 15 rounds that are bought, sold or transferred after July 1, 2013.

296. Many common and popular firearms come standard with magazines with a capacity larger than 15 rounds.

297. Firearms with magazines larger than 15 rounds are in common use for exercising the fundamental right of self-defense, the “central component” of Plaintiffs’ Second Amendment rights.

298. Disabled persons, including the Disabled Plaintiffs, are at a particular disadvantage in exercising their right of self-defense because their physical infirmities or confinement to a wheelchair means they can less effectively defend themselves or their families with fewer available rounds of ammunition, and are unable to quickly and safely change magazines.

299. Firearms with magazines larger than 15 rounds are commonly used for other lawful purposes, including sport shooting and target shooting.

300. Plaintiffs will be unable to legally replace magazines that they owned prior to the effective date of HB 1224, as those magazines wear out, break, or are damaged.

301. The Plaintiffs Federal Firearm Licensees and Magpul will be unable to sell many popular magazines or sell firearms in their standard configuration as supplied by the manufacturers.

302. Prohibition on a class of firearms or their accessories that are in common use for self-defense and other lawful purposes is specifically prohibited by the Second Amendment pursuant to *Heller*, and the incorporation of the Second Amendment right into the Fourteenth Amendment under *McDonald*.

## **SECOND CLAIM FOR RELIEF**

### **(HB 13-1224 – Violation of Second and Fourteenth Amendments Based on Prohibition of Magazines “Designed to Be Readily Converted”)**

303. Paragraphs 1 through 211 are re-alleged and incorporated herein.

304. In addition to the explicit prohibition on all magazines larger than 15 rounds, HB 1224 prohibits magazines of any size that are “designed to be readily converted” to hold more than 15 rounds.

305. Most magazines 15 rounds or smaller are manufactured with a removable floor plate (box magazines) or end cap (tube magazines) to facilitate maintenance and cleaning.

306. Magazines with a removable floor plate or end cap can be readily converted to hold more than 15 rounds. Even box magazines whose floor plate cannot be removed can be converted to hold more than 15 rounds, simply by duct taping two such magazines end to end.

307. HB 1224 bans magazines regardless of whether they actually have been converted to hold more than 15 rounds. A ten-round magazine is prohibited by HB 1224 even when it is used only by itself.

308. Tens of millions of rifles and handguns in common use for self-defense and other lawful purposes use magazines of various sizes that contain removable floor plates or end caps.

309. Many common rifles and handguns will be rendered effectively useless by the magazine prohibition. Replacing a magazine after the effective date of the statute will be prohibited, even where an individual wishes to change to a smaller magazine. Especially for firearms that are not in current production, it may be impossible for citizens to obtain a replacement magazine that complies with HB 1224.

310. The prohibition on most magazines puts disabled individuals, including the Disabled Plaintiffs, at particular risk because they will have far less ability to meaningfully defend themselves and their families, and far fewer firearms from which to choose.

311. A ban on the possession of a broad class of functional firearms, as specifically addressed by the Supreme Court in *Heller*, violates the Second Amendment as incorporated in the Fourteenth Amendment.

### **THIRD CLAIM FOR RELIEF**

#### **(HB 12-1224 – Violation of Fourteenth Amendment Right to Due Process Based on Ambiguity of Language Regarding Magazines 15 Rounds or Smaller)**

312. Paragraphs 1 through 220 are re-alleged and incorporated herein.

313. HB 1224 is unconstitutionally vague in violation of the Fourteenth Amendment right to Due Process.

314. Plaintiffs cannot determine whether a magazine with a removable floor plate or end cap to facilitate maintenance and cleaning was “designed to be readily convertible” to hold more than 15 rounds. Plaintiffs cannot possibly know the intent of the designers of all the magazines for the firearms which Plaintiffs own.

315. Law enforcement officers, including the Plaintiff Sheriffs, likewise have no means to determine the intent of magazine designers. Enforcement of the provision will be difficult, if not impossible, and will result in differing interpretations of the meaning of HB 1224 in different jurisdictions.

316. Licensed firearms retailers are likewise unable to ascertain design intent, and therefore do not know which magazines can be sold without risk of criminal prosecution.

317. Because of the ambiguity in the language and the likelihood of inconsistent interpretation and enforcement, individuals are chilled in the exercise of their Second Amendment rights.

318. A statute that is so vague that a person cannot clearly determine what conduct may result in criminal prosecution, or that will result in inconsistent application, thereby chilling the exercise of another constitutional right, violates the Fourteenth Amendment guarantee of Due Process of law.

## **FOURTH CLAIM FOR RELIEF**

### **(HB 12-1224 – Violation of the Second and Fourteenth Amendments; Requirement for “Continuous Possession” of Magazines Owned on the Effective Date)**

319. Paragraphs 1 through 227 are re-alleged and incorporated herein.

320. HB 1224 permits an individual to retain a magazine larger than 15 rounds or any prohibited smaller magazine that was owned prior to the effective date of July 1, 2013, so long as the magazine remains in that individual’s “continuous possession.” The statute thus explicitly prohibits the sale or temporary transfer of such magazines.

321. The term “continuous possession” is undefined.

322. Most magazines are essential to the operation of a firearm. HB 1224 prohibits any loan, even for a short period of time, of a firearm using a grandfathered magazine, including temporary loans among family members (such as allowing one’s spouse to use a firearm for self-defense – either while the owner is home, or while the owner is away from home), or loaning a magazine and the associated firearm to disabled neighbors or friends.

323. “Continuous possession” would also prohibit innocuous, routine bailments or breaks in the chain of custody of a grandfathered magazine, including leaving a magazine with neighbors or friends for safe storage while the owner is out of town, or sharing the magazine with another person who is also engaged in a shooting event in which the owner was participating.

324. “Continuous possession” is undefined and vague, and owners of a magazine cannot clearly determine what is required of them to maintain “continuous possession” and what conduct may subject them to criminal penalties.

325. Law enforcement officials will and do find it impossible to enforce this provision because it is impossible to determine whether a magazine was in possession of the owner on the statute’s effective date. Law enforcement offices have limited resources, and no reasonable investigation can determine the chain of custody for every magazine.

326. Because the term “continuous possession” is undefined and vague, enforcement will be inconsistent and subject to local interpretation and the predilections of individual officers or offices.

327. HB 1224’s “continuous possession” requirement chills individuals’ Second Amendment rights by subjecting them to the threat of criminal prosecution for routine, lawful sharing of firearms with covered magazines arising from varying interpretations of HB 1224 and inconsistent enforcement.

#### **FIFTH CLAIM FOR RELIEF**

##### **(HB 1224 and 1229 – Violation of the Americans With Disabilities Act)**

328. Paragraphs 1 through 236 are re-alleged and incorporated herein.

329. Title II of the Americans With Disabilities Act (“ADA”) prohibits public entities from subjecting persons with disabilities to discrimination because of their disabilities. 42 U.S.C. § 12132.

330. States, including the State of Colorado, are included within the ADA definition of public entity. 42 U.S.C. § 12131(1)(A).

331. Disabled individuals, including the Disabled Plaintiffs, are subject to discrimination by the prohibition on magazines in HB 1224 because they have far less ability to defend themselves than do able-bodied persons. Specifically, they are unable to change magazines as quickly, and unable to retreat to positions of safety where a magazine can be changed.

332. HB 1224 puts disabled persons in acute danger in the event of a home invasion or other confrontation requiring them to exercise their fundamental right to self-defense.

333. Persons with disabilities also routinely temporarily transfer firearms to one another and to and from persons who aid them in participation in shooting sports and self-defense.

334. HB 1229's restrictions of such temporary transfers restrain persons with disabilities from engaging in conduct that is essential to the exercise of their Second Amendment rights.

335. The right to self-defense is a fundamental right under the Second Amendment, and is applied to the states through the Fourteenth Amendment. The ADA prohibits states from engaging in such discrimination against disabled persons, particularly where it prevents the meaningful exercise of a fundamental right.

### **SIXTH CLAIM FOR RELIEF**

#### **(HB 13-12-1229 – Violation of the Second and Fourteenth Amendments Based on Restrictions of Firearms Sales and Temporary Transfers - Individuals)**

336. Paragraphs 1 through 244 are re-alleged and incorporated herein.



337. HB 1229 requires background checks prior to many temporary and non-commercial transfers of firearms between private individuals.

338. For example, the statute allows gifts or loans between some family members, but excludes many common family relationships, such as former spouses, other partners, stepchildren, and second cousins. Therefore, a person may not loan or give a firearm to a former spouse, even when the former spouse has temporary or permanent custody of the couple's children and needs the firearm for protection of the children.

339. Similarly, many temporary transfers are limited to 72 hours. Therefore, no person may loan a gun for legitimate purposes for longer than three days, such as for a disabled person to use while participating in a hunting or a sanctioned shooting event; or for a week-long loan to an individual to keep in her home when she is criminally threatened but has not yet had time to go to a gun store and begin the process of waiting three days (or sometimes longer) for the Colorado Bureau of Investigation to approve her purchase of a retail gun.

340. The prohibition of non-commercial, temporary transfers is an infringement of the Second Amendment.

341. Because of the reluctance of home-based Federal Firearms Licensees to do business with strangers, and the reluctance of storefront FFLs to perform a \$50 service for the statutory maximum fee of \$10, individuals who wish to sell or temporarily transfer firearms will find it impossible, or nearly so, to comply with HB 1229's requirement to obtain the services of a FFL.

342. In practice, therefore, HB 1229 amounts to a prohibition, rather than a regulation, of the covered sales and temporary transfers. As such, it is a violation of the Second Amendment right to bear arms, which includes the right to sell or temporarily transfer such arms.

### **RELIEF REQUESTED**

Plaintiffs pray that this Court:

A. Enter a declaratory judgment that the provisions of House Bill 13-1224, to be codified at C.R.S. § 18-12-301, that prohibit the sale, transfer or possession of magazines with larger than a 15-round capacity are a violation of the Second and Fourteenth Amendments of the United States Constitution, and are therefore void.

B. Enter a declaratory judgment that the provisions of House Bill 13-1224, to be codified at C.R.S. §§ 18-12-301 *et. seq.*, that ban the sale, transfer or possession of magazines of less than a 15-round capacity violates the Second and Fourteenth Amendments to the United States Constitution, and are therefore void.

C. Enter a declaratory judgment that the provision of House Bill 13-1224, to be codified at C.R.S. § 18-12-302, that requires continuous possession of magazines acquired before the effective date of the provision violates the Second and Fourteenth Amendments to the United States Constitution, and is therefore void.

D. Enter a declaratory judgment that the provision of House Bill 13-1224, to be codified at C.R.S. § 18-12-302, prohibiting the sale, transfer, or possession of magazines smaller than 15 rounds that are “designed to be readily converted to

accept more than 15 rounds” is vague, fails to give adequate notice of the conduct that may result in criminal penalties, may result in inconsistent enforcement, and prevents free exercise of Second Amendment rights in violation of Plaintiffs’ rights to Due Process of Law under the Fourteenth Amendment to the United States Constitution.

E. Enter a declaratory judgment that HB 1224 and HB 1229 violate Title II of the Americans With Disabilities Act.

F. Enter a declaratory judgment that HB 1229 violates the Second and Fourteenth Amendments to the United States Constitution, and is therefore void.

G. Issue preliminary and permanent injunctions enjoining Defendant John Hickenlooper and any officers, agents, and employees of the State of Colorado from administering or enforcing any provisions of HB 1224 and 1229 found to violate the United States Constitution or the Americans With Disabilities Act.

H. Award Plaintiffs attorneys’ fees and costs and grant other such relief as the Court deems proper.

Dated this ~~1st~~ 11<sup>th</sup> day of ~~July~~ December, 2013.

Respectfully submitted,

s/David B. Kopel  
INDEPENDENCE INSTITUTE  
727 E. 16th Avenue  
Denver, CO 80203  
Phone: (303) 279-6536  
Fax: (303) 279-4176  
david@i2i.org

**ATTORNEY FOR SHERIFFS AND DAVID  
STRUMILLO**

s/Jonathan M. Anderson  
Jonathan M. Anderson  
Douglas L. Abbott  
HOLLAND & HART LLP  
Post Office Box 8749  
Denver, CO 80201-8749  
Phone: (303) 295-8566  
Fax: (303) 672-6508  
jmanderson@hollandhart.com

**ATTORNEYS FOR MAGPUL INDUSTRIES AND  
THE NATIONAL SHOOTING SPORTS  
FOUNDATION**

s/Richard A. Westfall  
Richard A. Westfall  
Peter J. Krumholz  
HALE WESTFALL LLP  
1445 Market Street, Suite 300  
Denver, CO 80202  
Phone: (720) 904-6022  
Fax: (720) 904-6020  
rwestfall@halewestfall.com

**ATTORNEYS FOR DISABLED CITIZENS,  
OUTDOOR BUDDIES, INC., THE COLORADO  
OUTFITTERS ASSOCIATION, COLORADO**

**FARM BUREAU, WOMEN FOR CONCEALED  
CARRY, AND COLORADO YOUTH OUTDOORS**

s/Marc. F. Colin

Marc F. Colin

BRUNO COLIN JEWELL & LOWE PC

1999 Broadway, Suite 3100

Denver, CO 80202-5731

Phone: (303) 831-1099

Fax: (303) 831-1088

mcolin@bcjrpc.com

**ATTORNEY FOR LICENSED FIREARMS  
DEALERS**

s/Anthony J. Fabian

Anthony J. Fabian

LAW OFFICES OF ANTHONY J. FABIAN PC

501 Wilcox Street, Suite C

Castle Rock, CO 80104

Phone: (303) 663-9339

Fax: (303) 713-0785

fabianlaw@qwestoffice.net

**ATTORNEY FOR COLORADO STATE  
SHOOTING ASSOCIATION AND HAMILTON  
FAMILY ENTERPRISES, INC. D/B/A FAMILY  
SHOOTING CENTER AT CHERRY CREEK  
STATE PARK**

## Appendix

Diagram A. Detachable box magazine

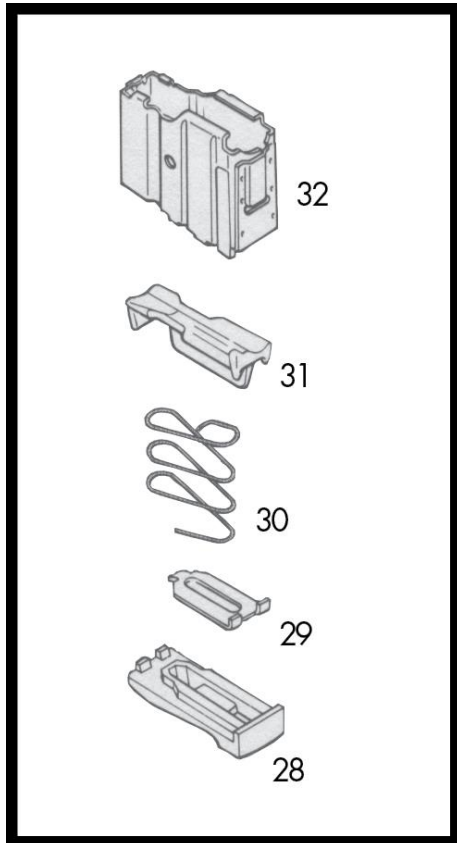

This is a detachable box magazine for the Ruger Mini-14 rifle. Parts are as follows:

32 = the shell. This is the box in which the ammunition is contained.

28 = floor plate. Sometimes called the “magazine bottom,” “base plate,” or “foot plate”. This Complaint uses “floor plate.”

29 = floor plate retainer. The retainer (29) holds the floor plate (28) onto the shell (32). There are many other ways to attach the floor plate to the magazine shell. For example, a pin might hold the floor plate in place; or the floor plate might fit into slots on the magazine shell.

30 = spring. When the magazine is fully loaded, the spring is fully compressed. When the firing chamber in the gun is empty, the spring pushes upward, so that the top round of ammunition in the magazine is pushed into the firing chamber.

31 = follower. The follower sits on top of the spring, and underneath the ammunition. It

provides a solid base for seating of the ammunition. When the magazine is loaded, several rounds of ammunition sit in a vertical stack on top of follower. The follower is on top of the spring, and the spring sits on the floor plate.

Diagram B. Tube magazine.

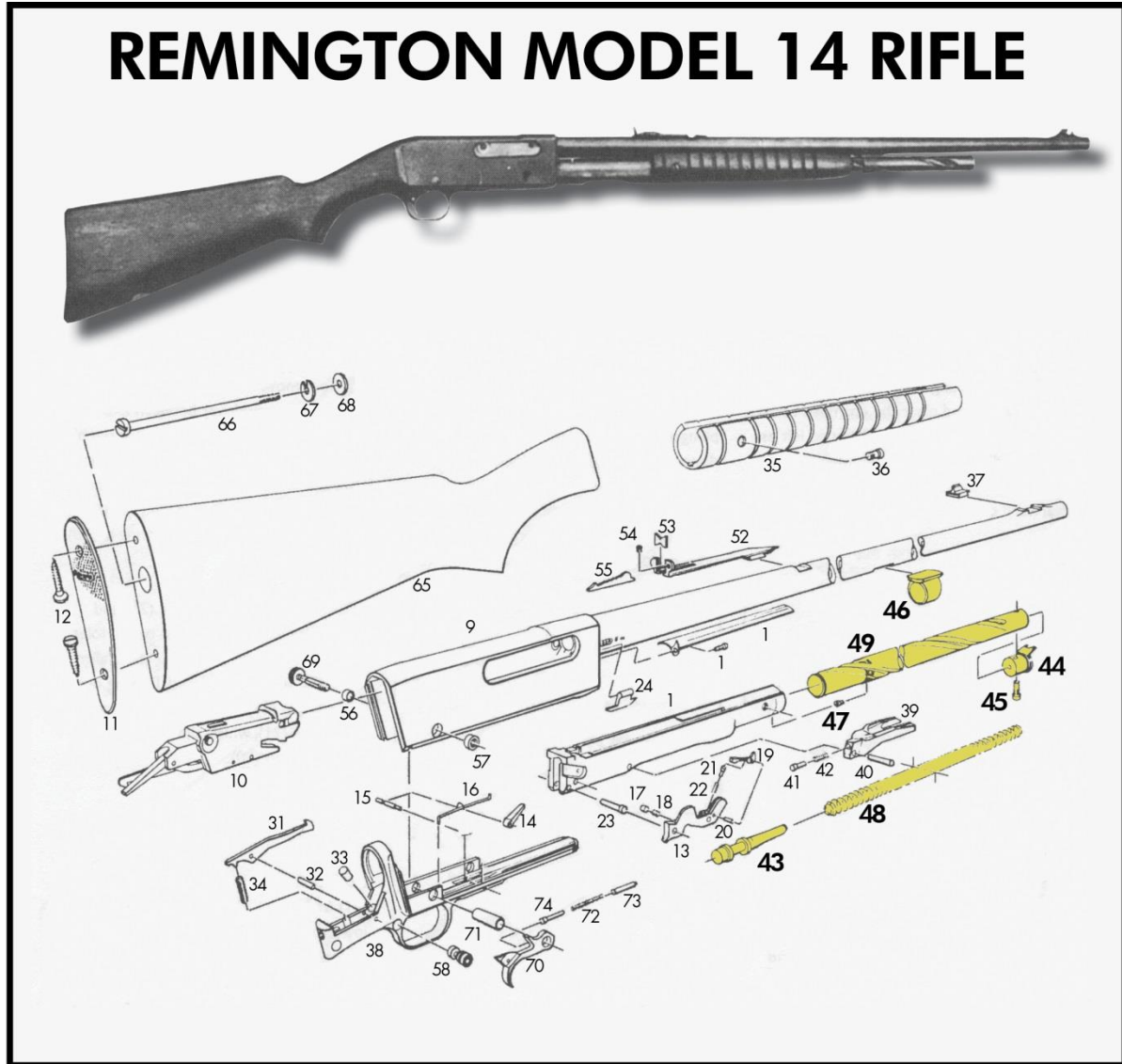

This is a schematic for the Remington Model 14. It is a pump-action rifle, first produced in 1912. The magazine parts are highlighted with color.

49 = magazine tube, which contains the ammunition.

44 = end cap. May also be called "magazine plug" or "removable plug." Similar in function to the floor plate in the detachable box magazine. Can be removed for disassembly and cleaning of the magazine. Can be replaced by an extender, which increases the ammunition capacity of the magazine.

45 = end cap screw (a/k/a “magazine plug screw”). Holds the end cap onto the magazine tube, and holds the front of the assembled magazine onto the front of the rifle barrel.

48 = spring. As ammunition is loaded into the magazine, the spring compresses. The spring is firmly seated on the end cap. After the shooter has fired a round by pressing the trigger, the user pumps the fore-end (35) forward and then back. This cycles the “action” of the pump-action gun, so that the empty shell is ejected from the firing chamber; then a fresh shell is pushed by the spring from the magazine and into the firing chamber.

43 = magazine follower. Same function as the follower in the box magazine. The ammunition is stacked in a horizontal line, with one round of ammunition touching the follower. The spring pushes the follower, which pushes the ammunition.

46 = magazine ring. Holds the middle of the magazine onto the middle of the rifle barrel.

The back of the magazine tube has threads so that the tube can be screwed into connection with the action bar (1), which fits inside the “receiver” (9).